



**SOFTWARE USER GUIDE**  
*(Tutorials)*

**Computational Fluid x-Dynamics (CFxD)**  
**(Version 2.07.15, May 9, 2026)**

## Contents

	Nomenclature	2
	Getting started	4
I.	Basic tutorials	5
	1. Flow in a pipe (incompressible internal flow)	5
	2. Flow around a car (incompressible external flow)	23
	3. Flow in a duct with heated rods (flow with heat transfer)	31
	4. Natural convection in a closed box (buoyancy-driven flow)	38
	5. Free jet in open air (compressible subsonic flow, $M < 1$ )	43
	6. Flow in a pipe with a butterfly valve (thin internal wall)	49
	7. Flow in a settling chamber (porous media)	54
	8. Transient flow around a cylinder (laminar vortex shedding)	61
II.	Advanced tutorials	66
	9. Flow with rotation (MRF)	66
	10. Conjugate heat transfer (CHT)	71
	References	76

## Nomenclature

Symbol	Dimension	Definition
$C_i, c_i$		model coefficients
$c_p$	$J/(kg \times K)$	specific heat capacity by constant pressure
$g_i$	$m/s^2$	gravity acceleration
$Kn$		Knudsen number
$k$	$m^2/s^2$	turbulent kinetic energy
$l$	$m$	characteristic length scale
$M$		Mach number
$m$	$kg$	mass
$Nu$		Nusselt number
$P_k$		turbulent production
$Pr$		Prandtl number
$Pr_t$		Prandtl turbulent number
$p$	$Pa$	static pressure
$R$	$J/(kg \times K)$	gas constant
$Re$		Reynolds number
$Sc$		Schmidt number
$T$	$K$	temperature
$t$	$s$	time
$u, u_i$	$m/s$	velocity vector/components
$\overline{u'_i u'_j}$	$m^2/s^2$	Reynolds stress tensor (components)
$\overline{u'_j \phi'}$		scalar flux (components)
$V$	$m^3$	volume
$x_i$	$m$	cartesian coordinates

### Greek letters

Symbol	Dimension	Definition
$\alpha_i, \beta_i, \delta_i, \gamma_i$		model coefficients
$\dot{\gamma}$		strain rate

$\Gamma_\varphi$		Molecular diffusion coefficient of a general scalar quantity, $\varphi$
$\delta_{ij}$		Cartesian components of unit tensor (Kronecker delta)
$\varepsilon$	$m^2/s^2$	dissipation rate of turbulent kinetic energy
$\lambda$	$J/(s \times K \times m)$	thermal conductivity
$\varphi$		general scalar quantity
$\kappa$		Karman constant
$\mu, \mu_t$	$kg/(m \times s)$	dynamic molecular/turbulent viscosity
$\nu, \nu_t$	$m^2/s$	kinematic molecular/ turbulent viscosity
$\rho$	$kg/m^3$	density
$\sigma$	$m^2$	surface
$\sigma_\varphi$		turbulent Schmidt (or Prandtl) number for variable
$\tau$	$s$	turbulent time scale
$\tau_{ij}$		Reynolds stress tensor (components)
$\omega$		specific dissipation rate

## Abbreviations

Abbreviation	Definition
CAD	Computer-aided design
CDS	Central Difference Scheme
CFD	Computational Fluid Dynamics
CV	Control Volume
DNS	Direct Numerical Simulation
EVM	Eddy-Viscosity Model
LES	Large Eddy Simulation
RANS	Reynolds Averaged Navier-Stokes
RSM	Reynolds Stress Model
SIMPLE	Semi Implicit Method for Pressure Linked Equations
UDS	Upwind Difference Scheme
URANS	Unsteady RANS

## Getting started

This document is an addition to Software User Guide (*Theory and general overview*). While the main guide explains the underlying physics, numerical methods, and software features, this document focuses on **practical, step-by-step tutorials** designed to help new users gain experience with CFXD.

The tutorials cover the complete workflow of a CFD simulation:

- Creating or importing geometry
- Generating a mesh
- Configuring physical models and boundary conditions
- Running the numerical solver
- Visualizing and interpreting results.

Each tutorial is organized to gradually introduce new concepts and tools in CFXD, allowing users to build confidence and familiarity with the software through hands-on examples.

These exercises are intended for:

- Students learning CFD fundamentals
- Engineers evaluating CFXD for practical use.

Throughout the tutorials, screenshots, tips, and explanations are provided to ensure that each step is easy to follow, even for users with limited or no CFD experience.

## Chapter I. Basic tutorials

This chapter presents introductory example cases covering **steady and transient** simulations for **incompressible** and **subsonic compressible ( $M < 1$ )** flows, with and without **heat transfer**.

### 1. Flow in a pipe (incompressible internal flow)

The configuration represents a pipe of 0.6 m diameter ( $D$ ) with a  $90^\circ$  bend and with upstream and downstream straight sections of length  $5D$  and  $10D$ . The inlet velocity is 2 m/s and the fluid is air. We can verify that flow is turbulent and incompressible by calculating  $Re$  and  $M$ .

$$Re = \frac{D_0 \cdot u_0}{\nu} = \frac{0.6 \cdot 2}{1.46 \cdot 10^{-5}} \approx 82000.$$

The Reynolds number is approximately 82000, which is greater than 2300 (flow is turbulent in straight pipes if  $Re > 2300$  [1]), so flow is turbulent.

$$M = \frac{u}{a} = \frac{u}{\sqrt{kRT}} = \frac{2}{\sqrt{1.4 \cdot 287 \cdot 288}} = 0.006.$$

Mach number is much smaller than 0.3 [1], so compressibility effects can be neglected.

Start CFxD from Windows Start menu or from Desktop icon. The program will be started with the **Geometry** Tab open. The default project main file projectN.cfxd (N- number) and required folders will be generated automatically.

### Geometry

There are the different ways to create a geometry. Here, the central curve, orthogonal circle surface, pull and combine operation will be used. Create the points to generate the center curve shown in Table 1.

*Table 1: Point coordinates to create the center line.*

Point	Coordinates	Comments
Pnt1	(0.0, 0.0, 0.0)	Start point of upstream pipe
Pnt2	(3.0, 0.0, 0.0)	End point of upstream pipe (Start point of arc)
Pnt3	(3.0, 0.6, 0.0)	Center of arc
Pnt4	(3.6, 0.6, 0.0)	Start point downstream pipe (End point of arc)
Pnt5	(3.6, 6.6, 0.0)	End point of downstream pipe

Point creation is shown in Figure 1. In the **Geometry creation** panel, select **Create point** (1). Enter the point's coordinates in **Coordinates input** panel (2). The empty input will be automatically recognized as 0.0. Generate a point with **Create point** button (3). Any created

geometry will appear in **Geometrical entities** tree (4) and will be displayed in the **Geometry view** window (5). Helpful hints are shown in the **status bar** at the bottom (6).

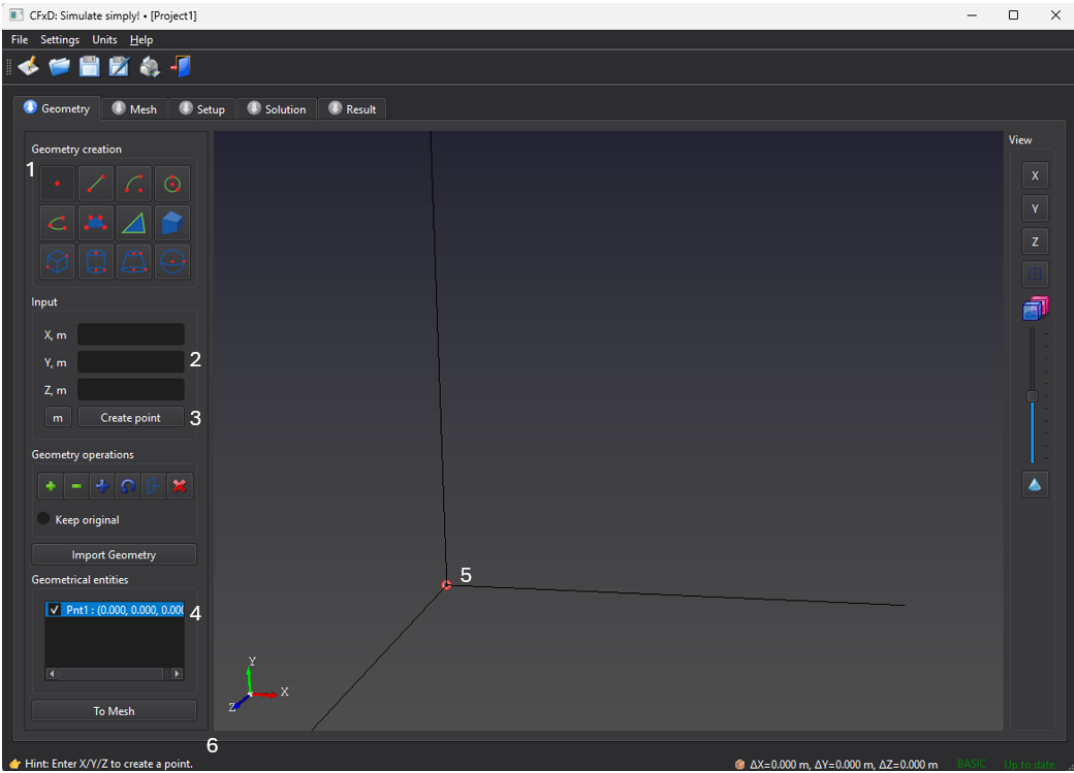

Figure 1. Point creation.

All five points are shown in Figure 2.

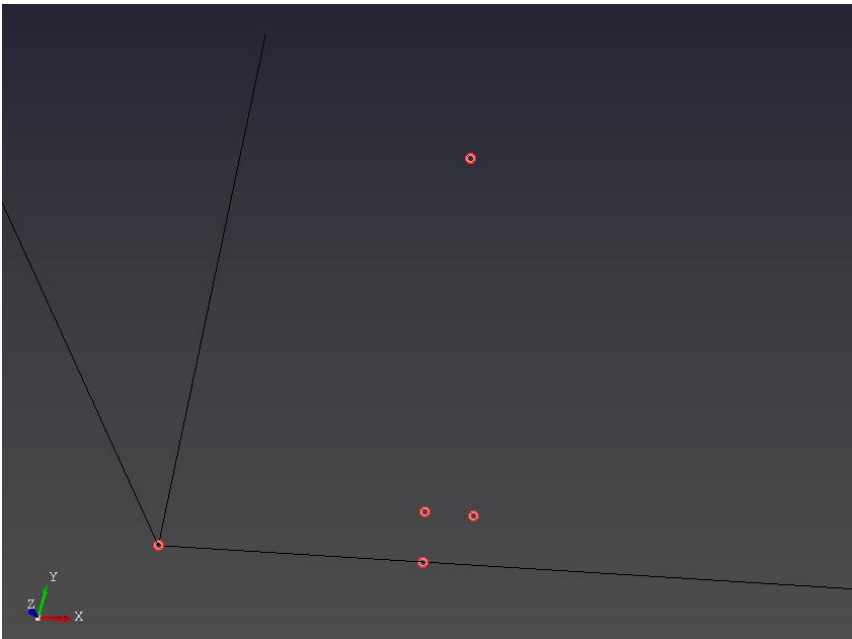



Figure 2. Five created points.

The next step is to create lines  by selecting two points and arc  by selecting three points with left mouse button (LMB). For an arc, the selection order is center point → start arc point → end arc point.

The hint on the bottom of screen can be used for guidance. The created two lines and arc are shown in Figure 3. Any selection can be discarded with LMB on empty screen.

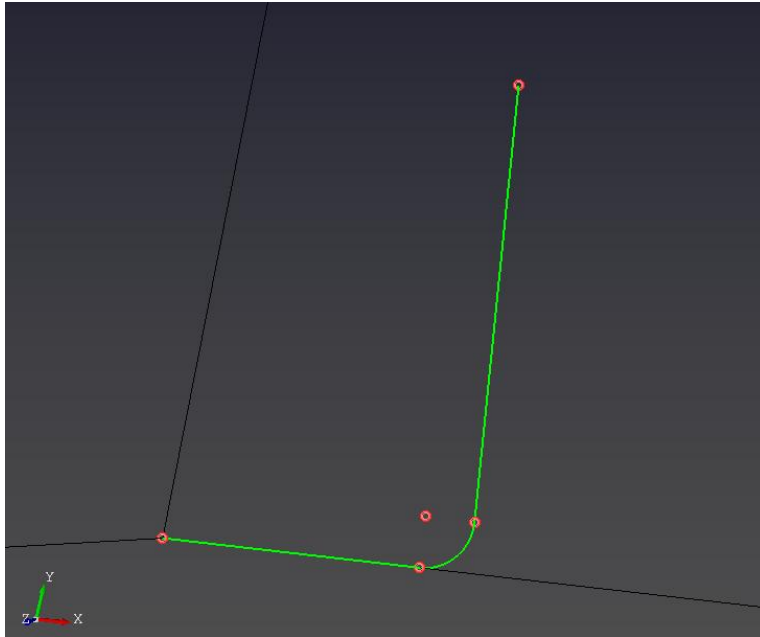

Figure 3. Created lines and arc.

Create two additional points (Table 2) to define a circle lying in the YZ plane. The points can be generated without switching back to the **Create point** tool. As the center point the Pnt1 will be used.

Table 2: Points coordinate for the circle.

Point	Coordinates	Comments
Pnt6	(0.0, 0.3, 0.0)	First point on circle
Pnt7	(0.0, 0.0, 0.3)	Second point on circle

The new points are shown in Figure 4.

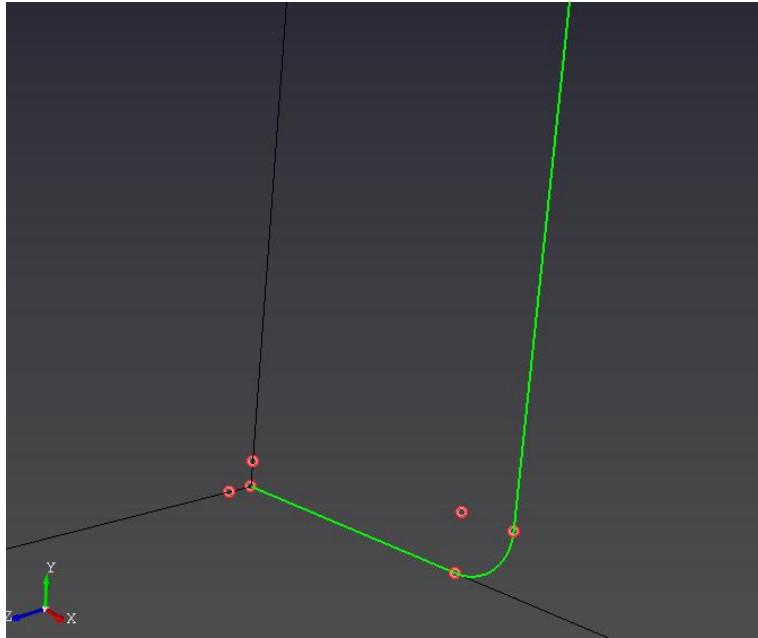



Figure 4. Points for circle creation.

Click on **Create circle** tool  and select three points in the following order: center of circle → first point on circle → second point on circle. The created circle is shown in Figure 5.

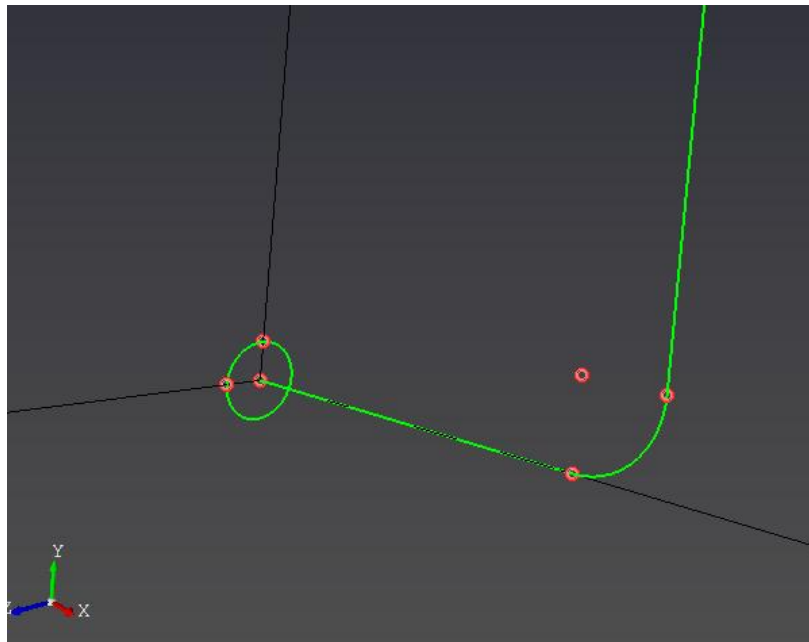

Figure 5. Circle creation.

Click the **Create surface** tool and select the circle. Since the circle forms a closed loop, a surface will be created (Figure 6).

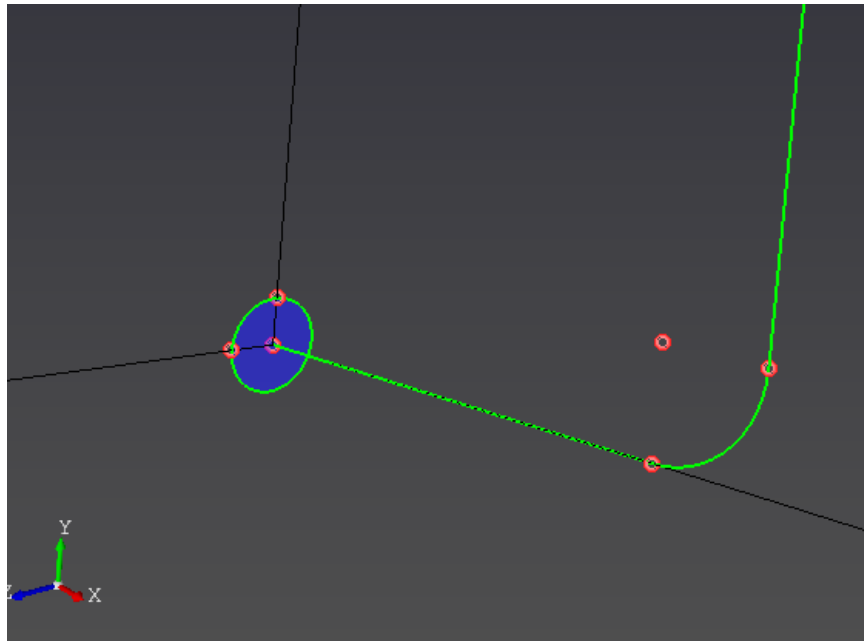



Figure 6. Circular surface generation.

The current geometry can be saved with **Save** icon in the toolbar, from the menu or with Ctrl+S keys.

Activate a **Pull** tool  in the **Geometry operations** panel. Select the circular surface and the line attached to it. A body will be created automatically (Figure 7).

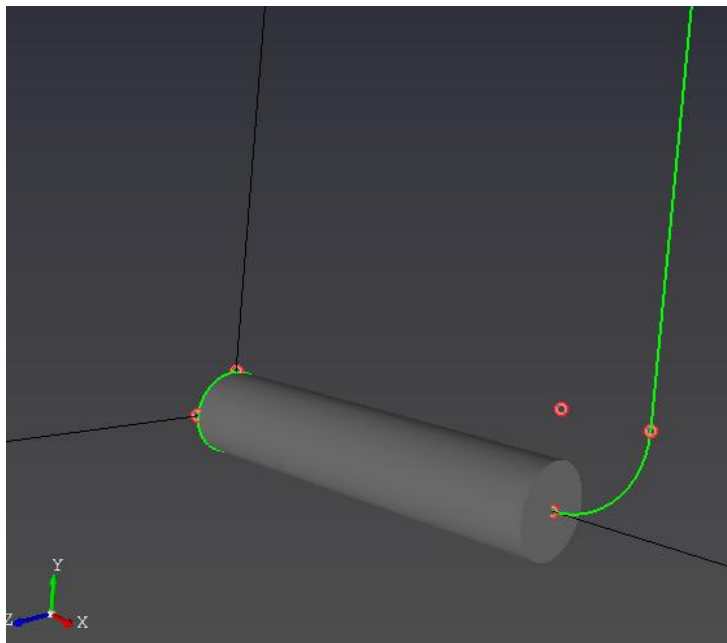

Figure 7. Cylinder creation using Pull operation.

Repeat the same procedure for bend section and the downstream pipe (Figure 8).

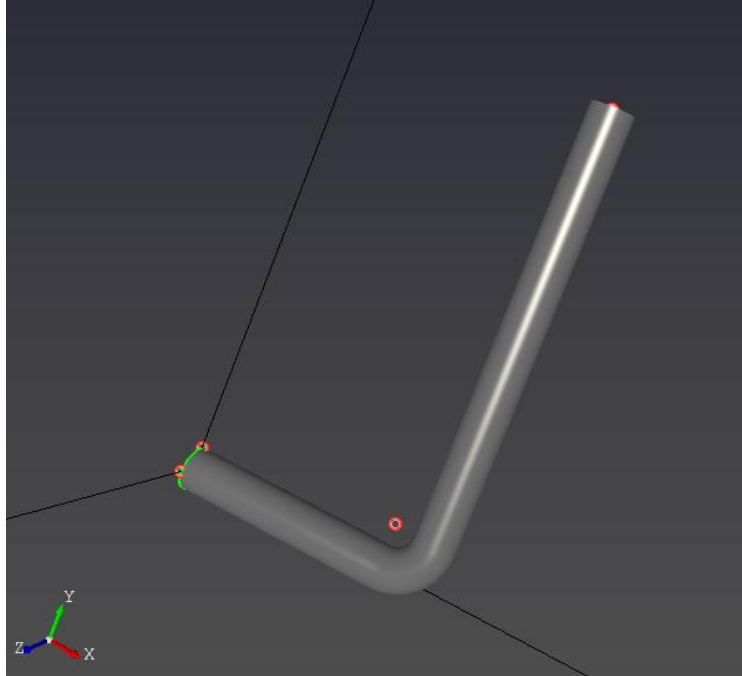



Figure 8. Upstream, bend and downstream pipes.

At this stage, there are three separate bodies. Click on Boolean operation: unite , keep **Keep original** unchecked, and select the upstream and bend bodies. A new united body will be created, and the originals bodies will be removed. Repeat the same operation with newly united body and the downstream pipe (Figure 9).

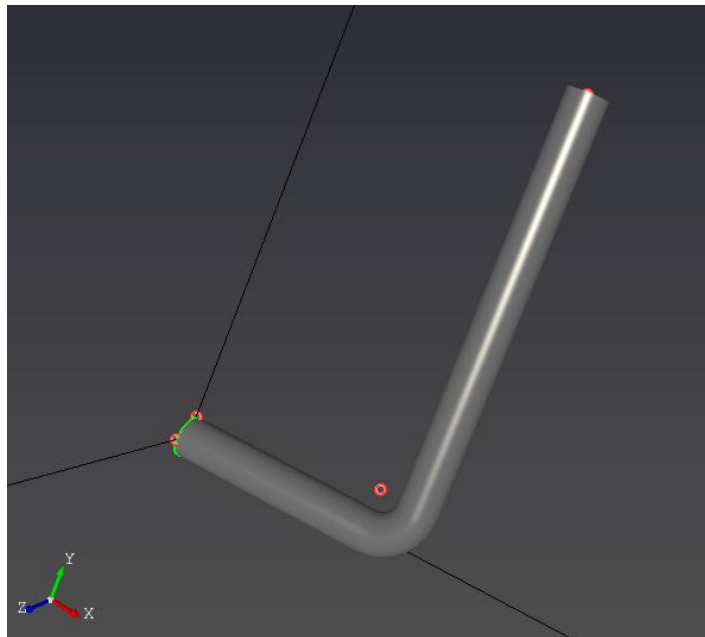

Figure 9. Final pipe geometry.

Enable **Face naming** mode by right-clicking RMB in the **Geometry view** window. The mouse cursor will change to a crosshair. Right-click the face at the inlet side of the pipe and name it **inlet** in the dialog (Figure 10). The assigned names will appear in the **Geometrical entities** tree.

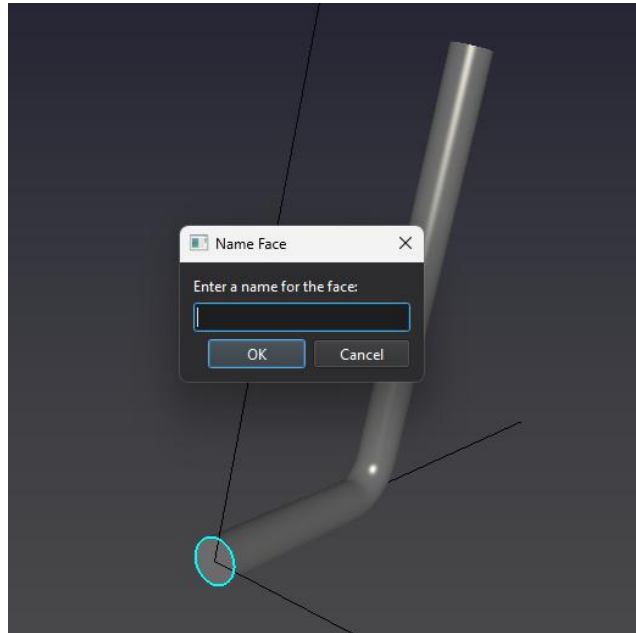

Figure 10. Face naming.

Similarly, name the exit face **outlet**. All remaining faces will be automatically assigned as **wall**. Click **To Mesh** to proceed to the next stage. The program will save all required files and the current state.

## Mesh

The **Mesh** generation tab is shown in Figure 11.

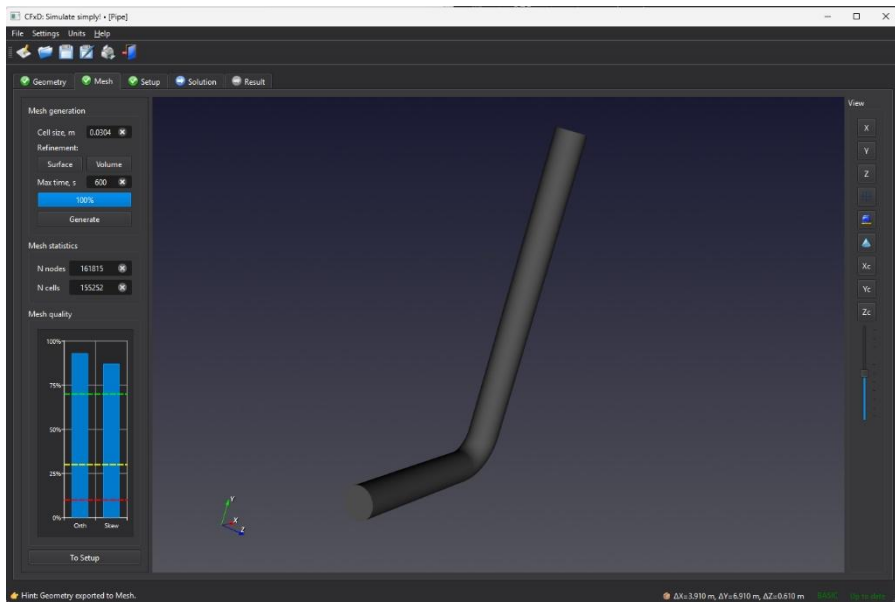

Figure 11. Mesh generation tab.

Keep the default pre-calculated **Cell size** (0.0304) and click on **Surface** or use RMB in **Mesh Viewer** to call Surface refinement dialog. Select **wall**, keep the default **Local cell** and enable **Layers** to generate prism (boundary-layer) layers near the walls. Use **Preview** to see the selected geometry and cell size (Figure 12). After it **Add wall**. Finally, **Apply and Close** dialog.

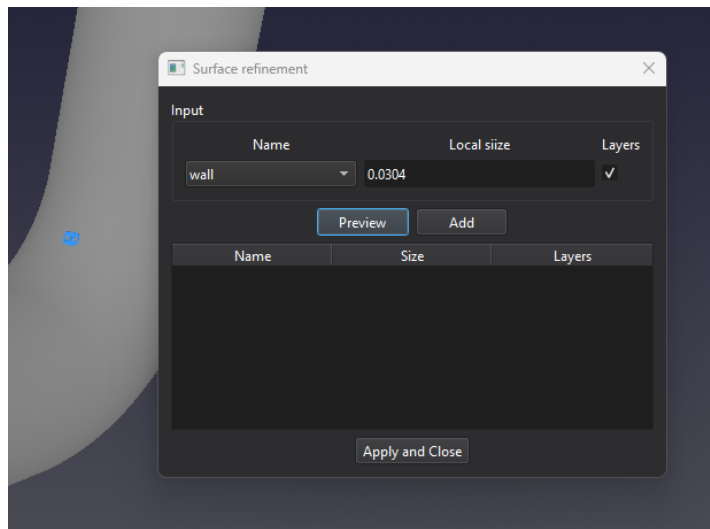

Figure 12. Set layers for wall.

Keep the default **Maximum time** 600 s. In this case the mesh generation process will stop automatically when the time limit is reached. Finally, click **Generate**. The generated mesh is shown in Figure 13.

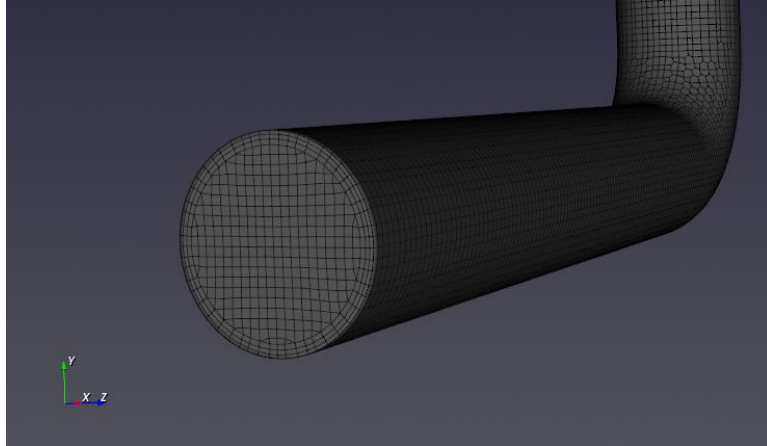

Figure 13. Generated mesh.

The number of generated nodes and cells can be checked in **Mesh statistics** panel. Mesh quality is shown as histograms of orthogonality (**Orth**) and skewness (**Skew**), along with quality thresholds (Figure 14).

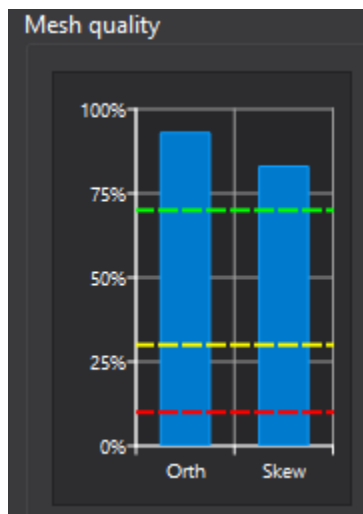

Figure 14. Mesh quality graph.

To inspect the mesh inside pipe, use **Section cut** buttons  $x_c$ ,  $y_c$ ,  $z_c$  on the right side of the window (Figure 15). The cut position can be adjusted using the slider.

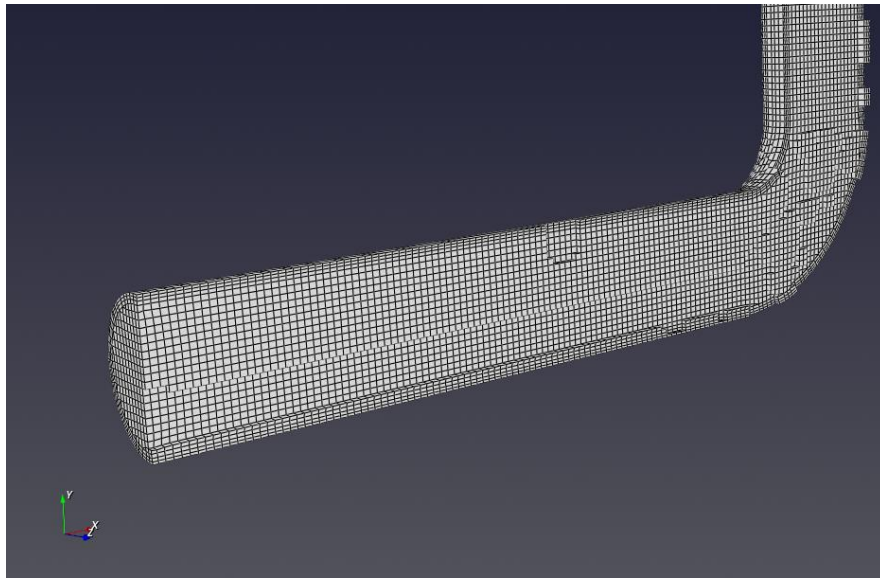

Figure 15. Mesh cut in Zc-direction.

Small visual artefacts may appear on the cut plane due to imperfect alignment between the cut and the mesh cells.

Click **To Setup** to proceed to the next stage.

## Setup

The **Setup** tab is shown in Figure 16.

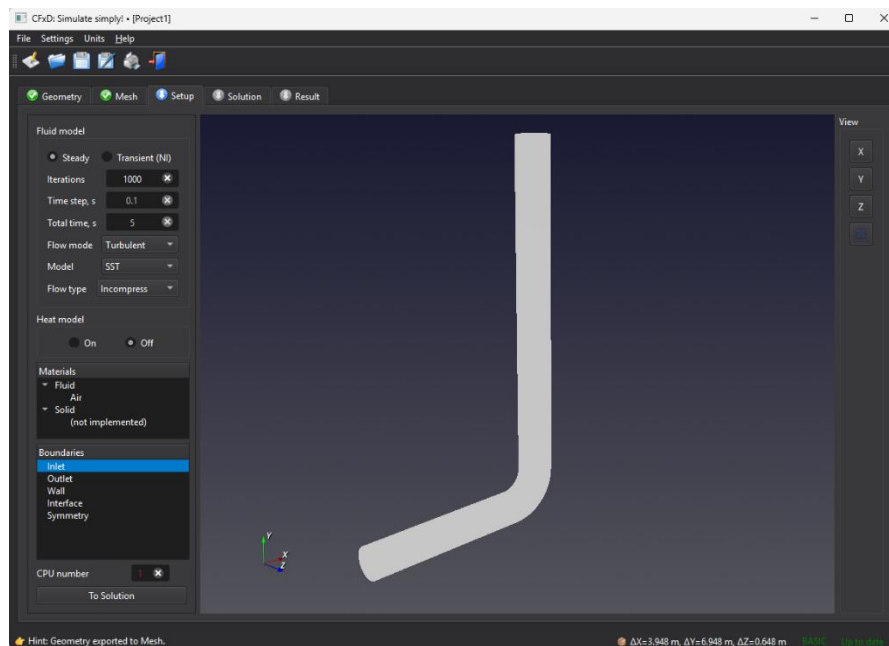

Figure 16. Setup Tab.

Keep the default settings in the **Fluid model** panel:

- **Steady** flow
- **1000** iterations
- **Turbulent** flow mode
- **SST** turbulent model
- Incompressible (**Incompress**) flow.

There is no heat transfer in this case so set **Heat** to **Off**. Keep the default **Fluid** in the **Material** tree: **Air**. In the **Boundaries** tree, click on **Inlet**. In the **Inlet** dialog, set:

- **x-Velocity**: 2 m/s
- **Length scale**: 0.6 m (pipe diameter)
- all other inputs are default.

Click **Apply** to save the changes (Figure 17).

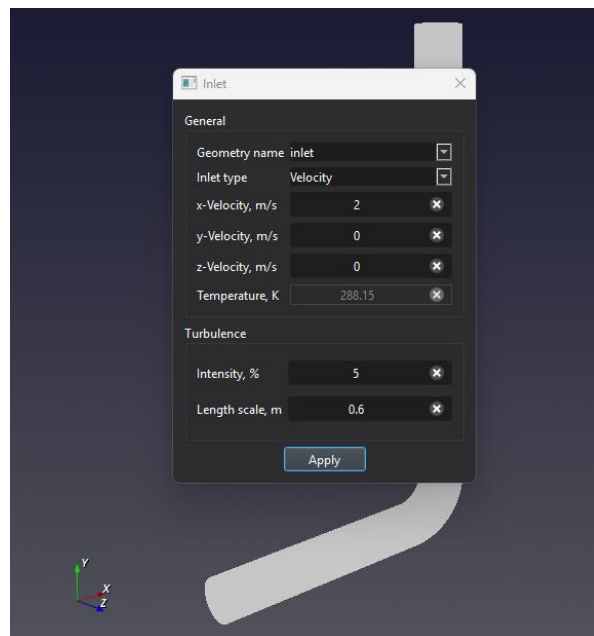

*Figure 17. Setup of inlet boundary conditions.*

Similarly, open the dialogs for **Outlet** and **Wall** and keep the default parameters. Because the faces were named **inlet** and **outlet** in the **Geometry** stage, the boundary-condition dialogs are automatically linked to the correct patches. After assigning the boundary conditions, the faces are color-coded in **Mesh view** window: **green** for **inlet**, **blue** for **outlet** and **dark gray** for **wall** (Figure 18).

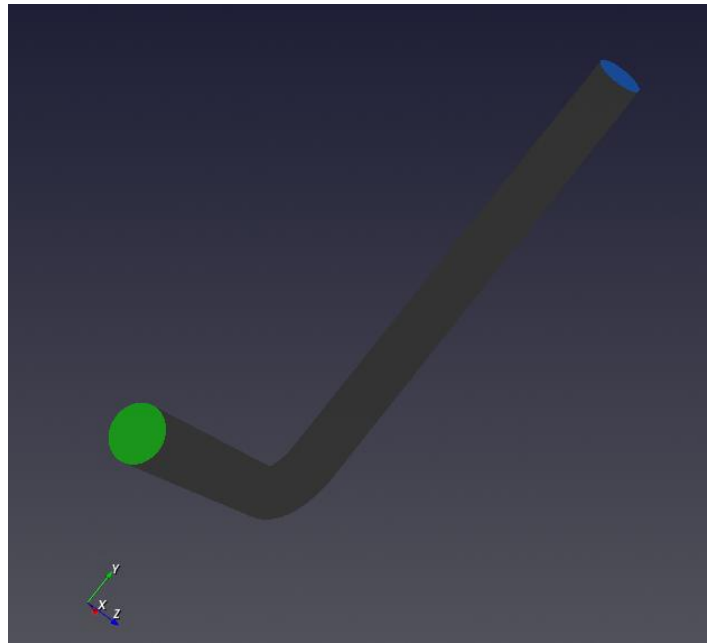

Figure 18. Final setup boundaries.

Keep the default number of CPU cores (1). Click **To Solution** to proceed.

## Solution

The **Solution** tab is shown in Figure 19.

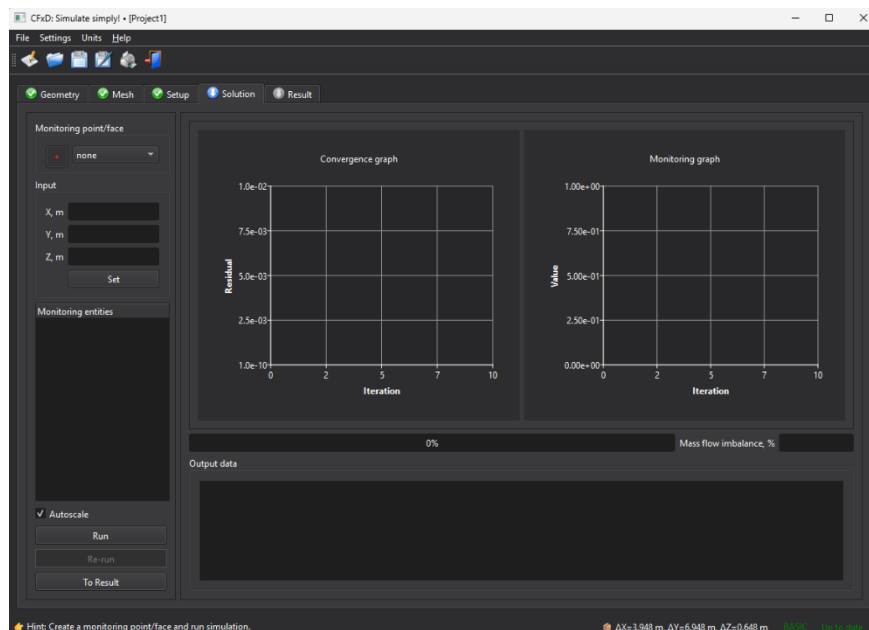

Figure 19. Solution tab.

In **Monitoring point/face** panel, select **Outlet** (instead of **none**). The outlet entity will appear in the **Monitoring entities** tree. Click **Outlet** to open the variable selection dialog. Select **Umag** and click **Apply** (Figure 20).

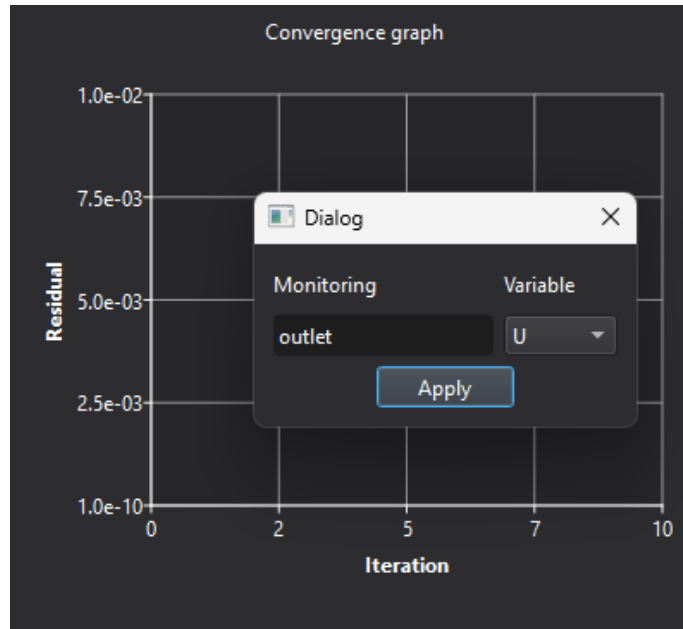

Figure 20. Setup of monitoring face at outlet.

In **Input** panel, set  $X = 3.6$ ,  $Y = 6.0$ ,  $Z = 0.0$  and click **Set** to create a monitoring point. Click the new point in the **Monitoring entities** panel, assign the monitoring variable **Umag**, and confirm with **Apply**. Start the simulation by clicking **Run**. A converged solution is shown in Figure 21.

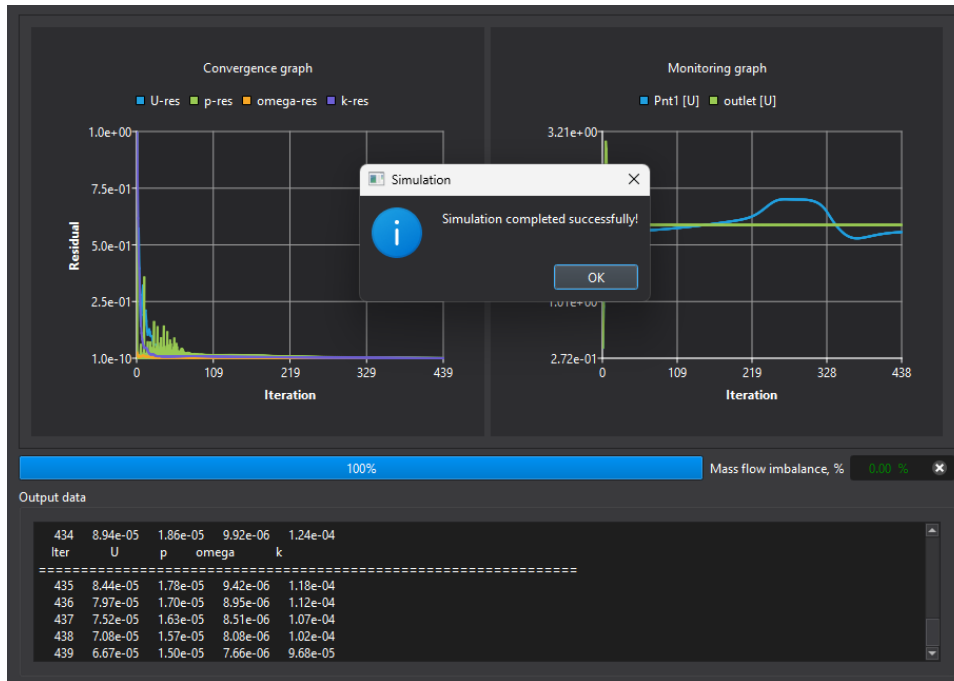

Figure 21. The completed simulation.

Residual values can be inspected in the **Output data** panel and on the convergence graph. Click **To Result** to proceed to the Result tab.

## Result

The **Result** tab is shown in Figure 22.

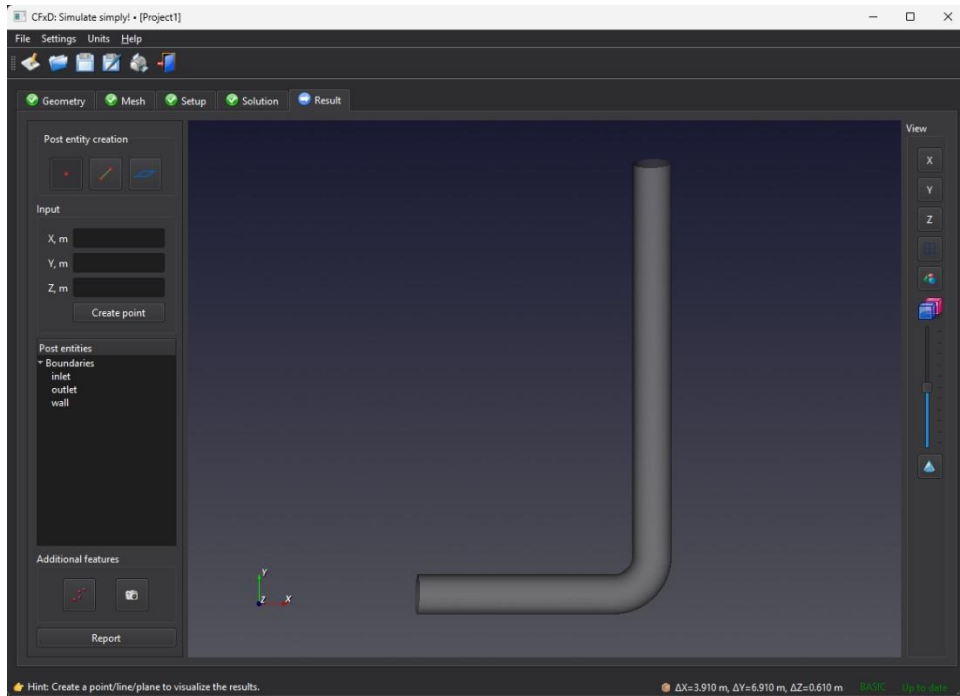

Figure 22. Result tab.

In the **Post entity creation** panel, click on **Create point** button (active by default). Create a point at  $X = 3.6$ ,  $Y = 6.0$ ,  $Z = 0.0$  using the **Input** panel. The point will appear in the **Post entities** tree and **Result view** window. Click on point **Post entities** tree to open the dialog and view values at that location. The three-velocity components at the selected point are shown in Figure 23.

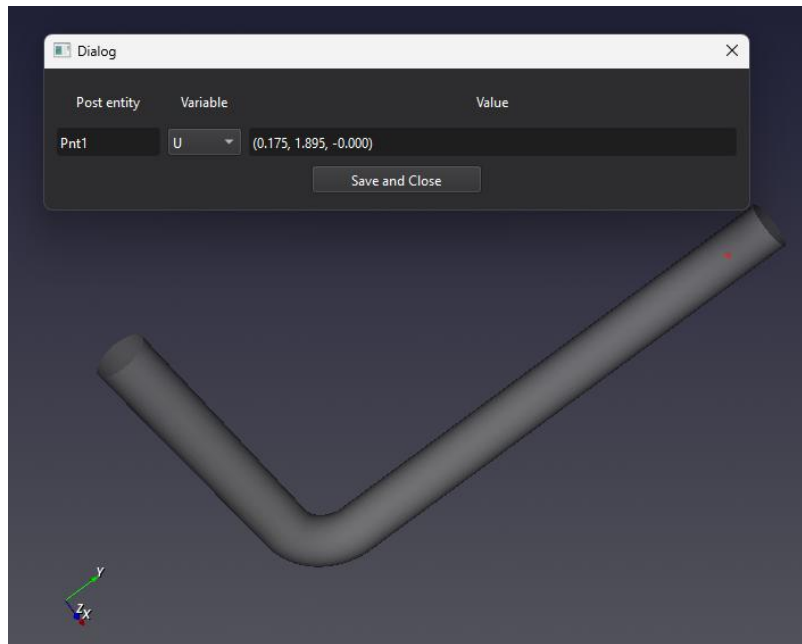

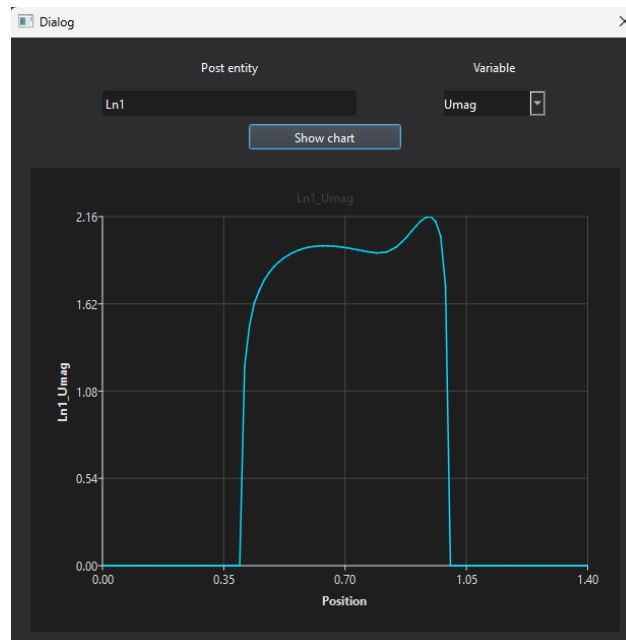

Figure 23. Velocity components value at selected point.

Click **Create line** button  in the **Post entity creation** panel to generate a line plot. Define the line using two points:

- Point 1:  $X = 2.9, Y = 6.0, Z = 0.0$
- Point 2:  $X = 4.3, Y = 6.0, Z = 0.0$

The line will appear in the **Result view** window and in the **Post entities** tree. Click the line in the tree to open its dialog. Select velocity **Umag** and click **Show chart** (Figure 24).



*Figure 24. Velocity profile at selected line.*

Create a plane using the **Plane** button . Keep the default coordinates to create XY plane at  $Z = 0$ . In the plane dialog, select velocity **Umag** and click on **Close and show** to display the contour plot in the **Result view** window (Figure 25).

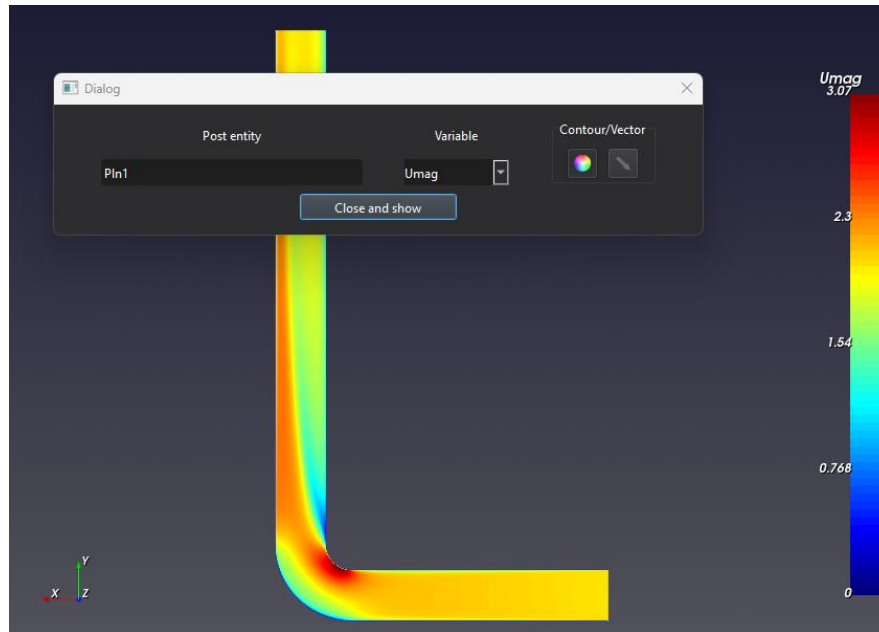

Figure 25. Velocity contour on the mid-plane ( $XY, Z=0$ ).

Boundary patches are added automatically to the **Post entities** tree. Click **wall**, then in the dialog select **pAbs (absolute pressure)**. The pressure distribution on the wall is shown in Figure 26.

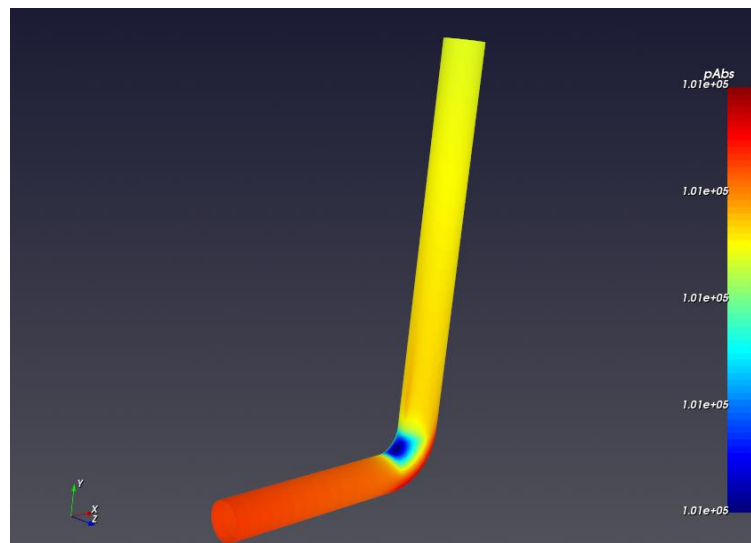

Figure 26. Absolute pressure on the wall.

Finally, click **Report**. A PDF report will be generated automatically (Figure 27) and saved in the **Result** folder. The project will be saved as well.

# CFxD Simulation Report

**Project:** Project1

**Path:** C:\CFxD\Projects\Project1

**Date:** 2026-01-30 15:52:50

## Geometry

### Statistics

- Solids: 1
- Faces: 6
- Edges: 11
- Vertices: 18

## Mesh

### Statistics

- Cells: 102338
- Nodes: 107704

### Quality

- Orthogonality ( $\geq$  threshold): 93 %
- Skewness ( $\leq$  threshold): 83 %

*Figure 27. Generated report.*

## 2. Flow around a car (incompressible external flow)

This tutorial uses a prepared simplified car model in **STEP** format. For external aerodynamics, the car must be placed inside a rectangular **computational domain**. The car speed is **200 km/h** ( $\approx 55 \text{ m/s}$ ). Start CFXD from Windows menu or desktop icon.

### Geometry

Import the **car** CAD model (STEP format). In CFXD, click **Import Geometry** (Figure 28), locate **car.stp** and open it.

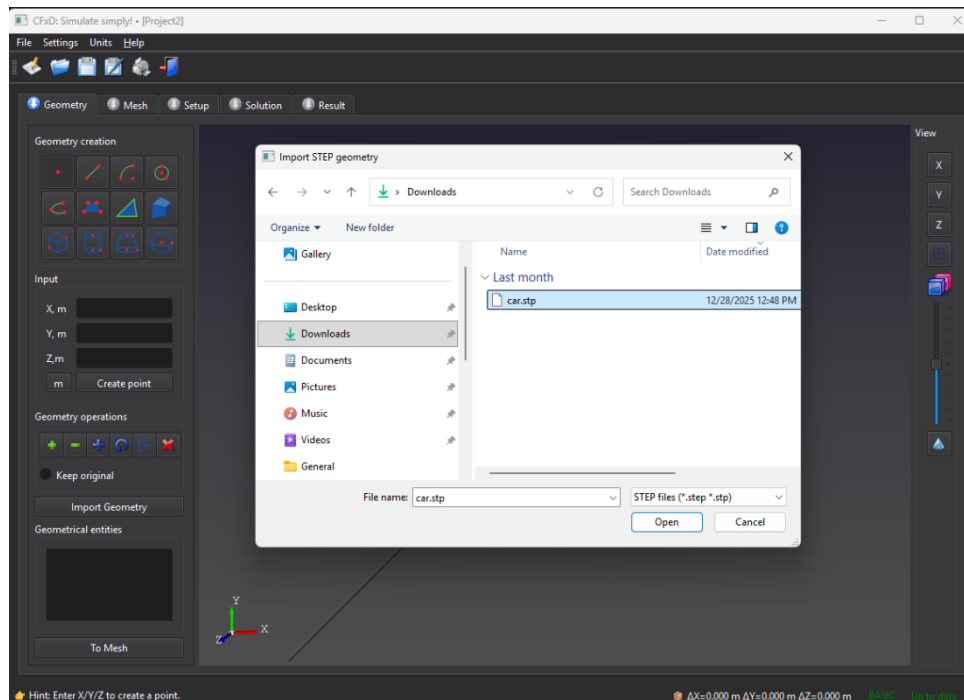

Figure 28. Importing geometry.

To model flow around a car, create a box enclosure. Use the **Box** tool from **Geometry creation** panel. Create two corner points (Table 3). These points define opposite corners of the enclosure (Figure 29).

Table 3: Points required to generate a domain.

Point	Coordinates	Comments
Pnt1	(9.25, 5.0, 0.0)	First corner point of the box
Pnt2	(-6.25, 0.0, 5.0)	Second corner point of the box

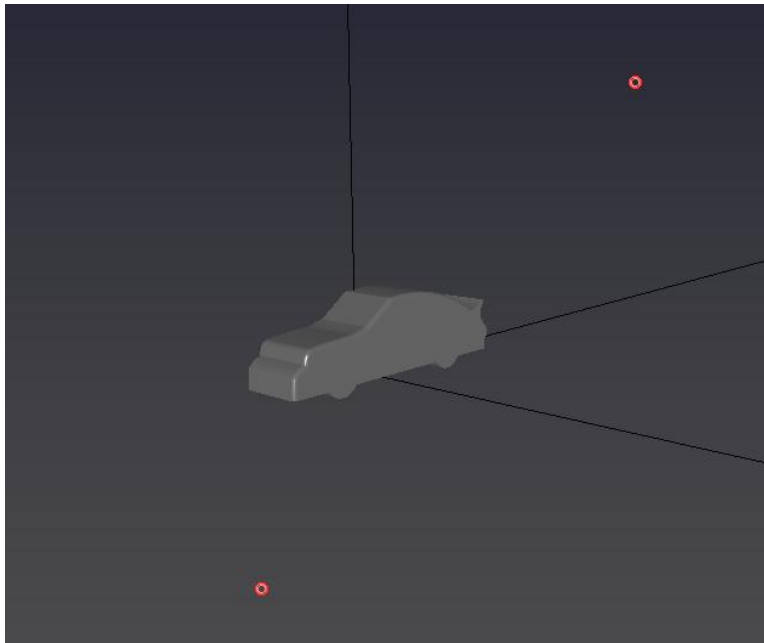

Figure 29. Corner points of domain.

Click **Box** in the **Geometry creation** panel and select the two points (Figure 30).

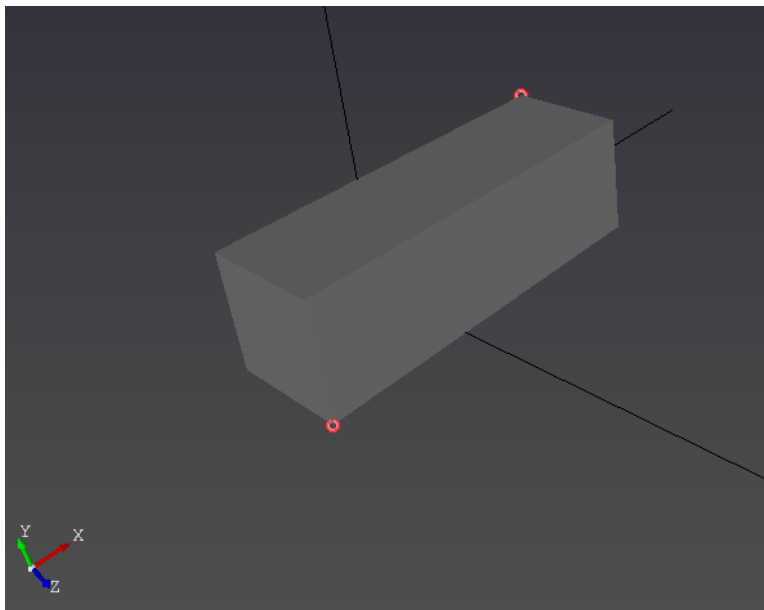

Figure 30. Created domain.

Next, subtract the car body from the enclosure so that only the **fluid domain** remains. In the **Geometry Operations** panel, click **Subtract**. Select the **enclosure** first. Then hide the enclosure in the **Geometrical entities** tree by unchecking its visibility box. With the enclosure hidden, select the **car body** to subtract it from the enclosure. The resulting body is shown in Figure 31.

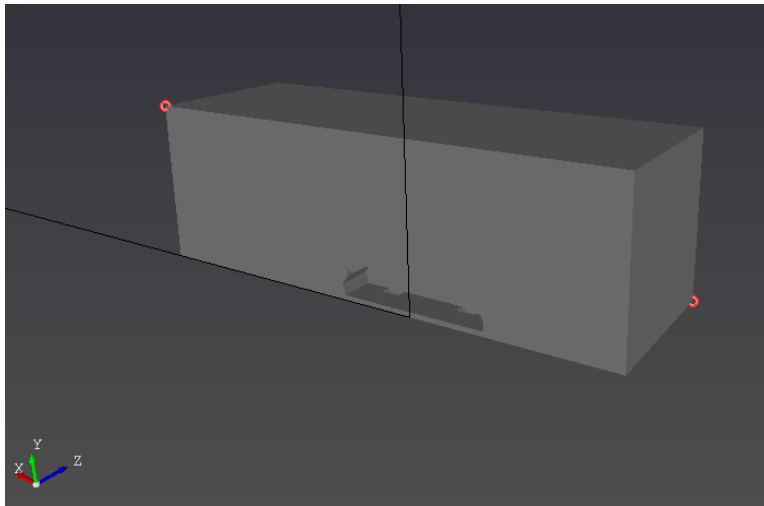

Figure 31. Final fluid domain.

Activate naming mode with **RMB** on an empty area in the graphical window. Name the **front face** of the domain **inlet** (Figure 32).

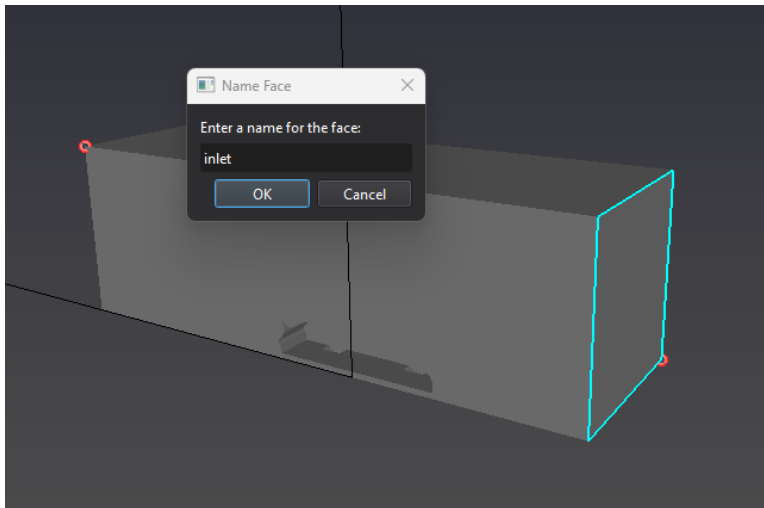

Figure 32. Naming the front face "inlet".

Name the **center symmetry face** as **symmetry-center**. Name the **top** and **side** faces as **symmetry**. To name multiple faces at once, hold **Ctrl** and select faces with **RMB**. You can still rotate the model using **LMB**. Releasing **Ctrl** opens the naming dialog (Figure 33). Two separately named symmetry faces are only required for post-processing.

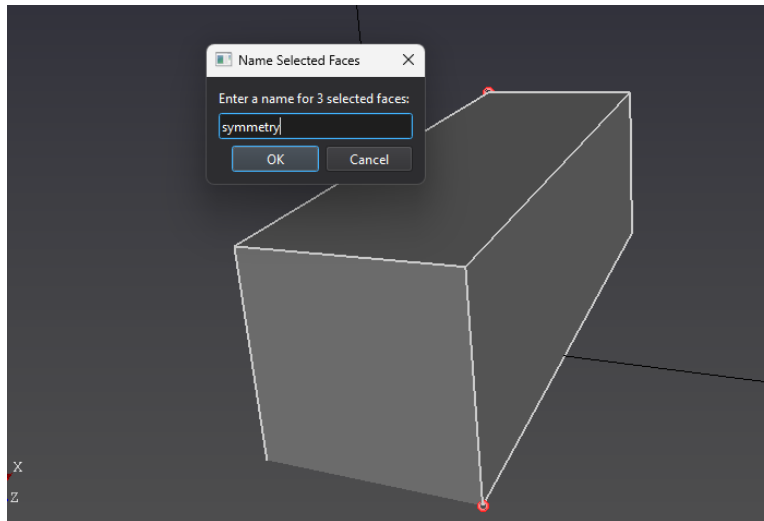

Figure 33. "Symmetry" name for the top and side faces.

Finally, name the rear face **outlet** (Figure 34).

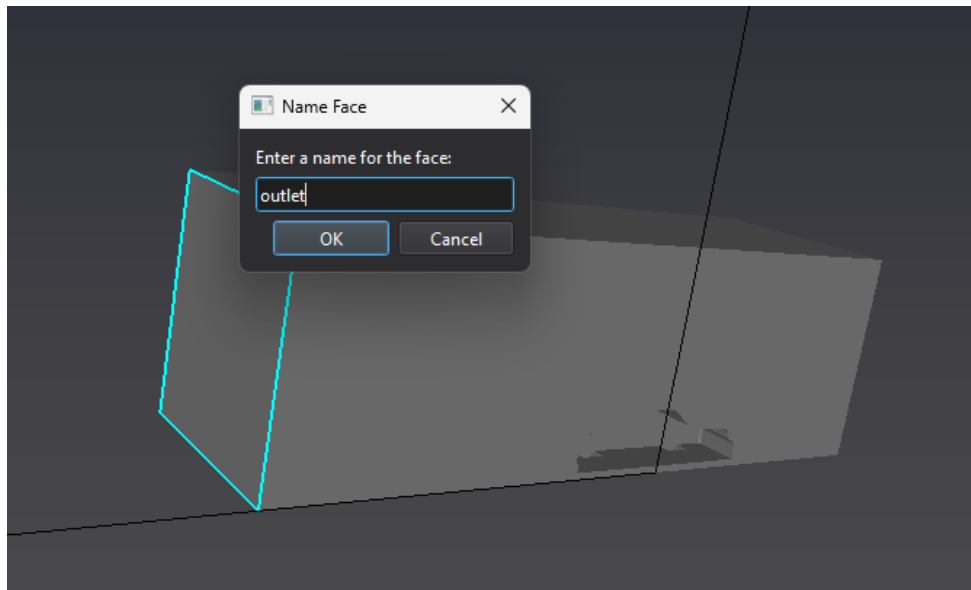

Figure 34. Naming the back face "outlet".

The remain face (ground) will be automatically named **wall**. Click **To Mesh** to proceed.

## Mesh

Set **Refinement** level = 1. Keep the remaining default mesh settings (**Cell size**: 0.156, **Wall treatment**: no, **Max time**: 600) and click **Generate**. The generated mesh shown in (Figure 35).

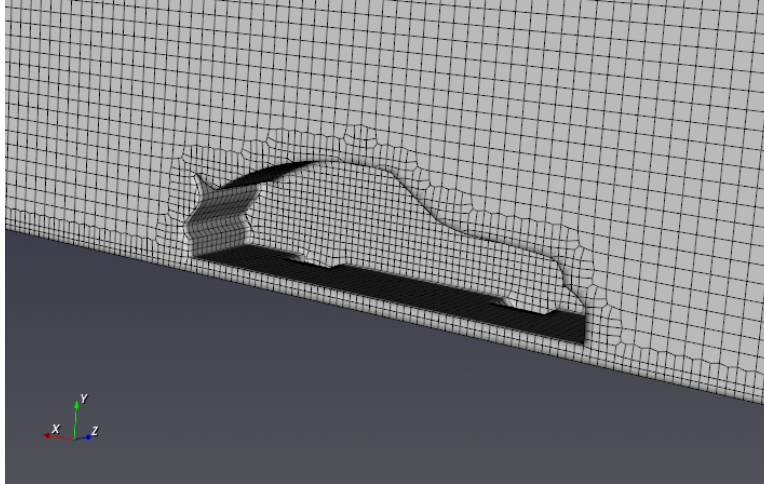

Figure 35. Generated mesh.

Click **To Setup** to continue.

### Setup

Keep the default **Fluid model** settings. Ensure **Heat transfer** = Off and the material is **Air**. In the **Boundaries** tree click **inlet** and set **x-Velocity** = 55 m/s, and **Length scale** = 5 (Figure 36).

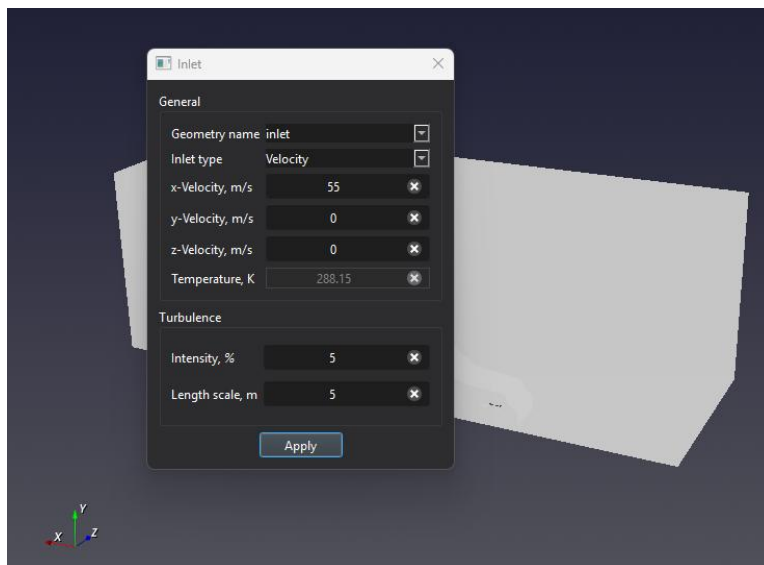

Figure 36. Inlet boundary conditions.

For **Outlet**, **Wall** and **Symmetry**, keep default parameters. Since two symmetry patches (**symmetry** and **symmetry-center**) were created, apply symmetry settings to both. All boundary conditions are shown in Figure 37.

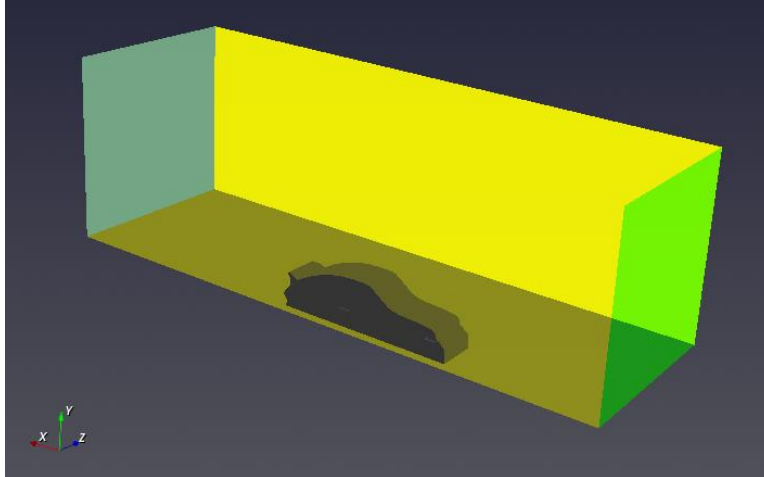

Figure 37. Boundary conditions.

Click **To Solution**.

### Solution

Create a monitoring point using the coordinates in Table 4. Then click the point in the **Monitoring entities** tree and assign the variable **Umag** or **Ux**.

Table 4: A monitoring point.

Point	Coordinates	Comments
Pnt1	(3.0, 0.5, 0.0)	Monitor point behind the car

Click **Run** to start the simulation. When finished (Figure 38), click **To Result**.

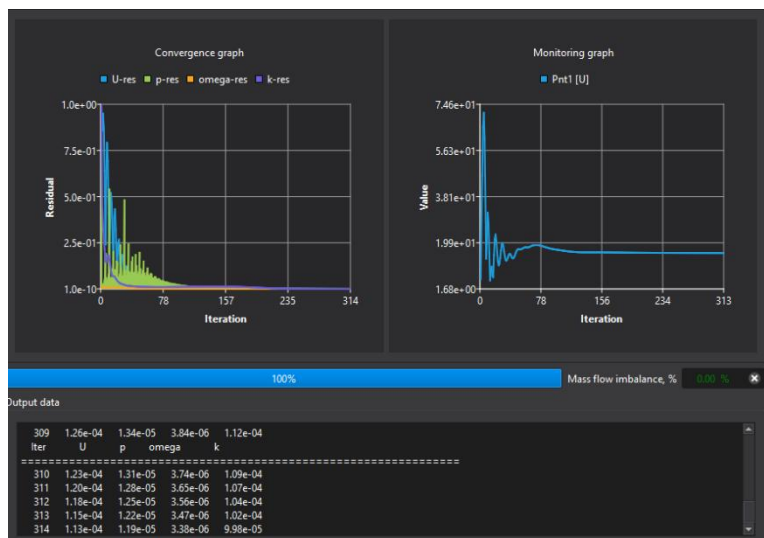

Figure 38. Finished simulation.

## Result

Create a plane at  $y = 0.5$  and display **Ux** on it. In the **Post entities** tree, expand the **Boundaries** category and click **symmetry-center**. In the dialog, select **Ux** (velocity x-component). Both contours will be displayed together (Figure 39).

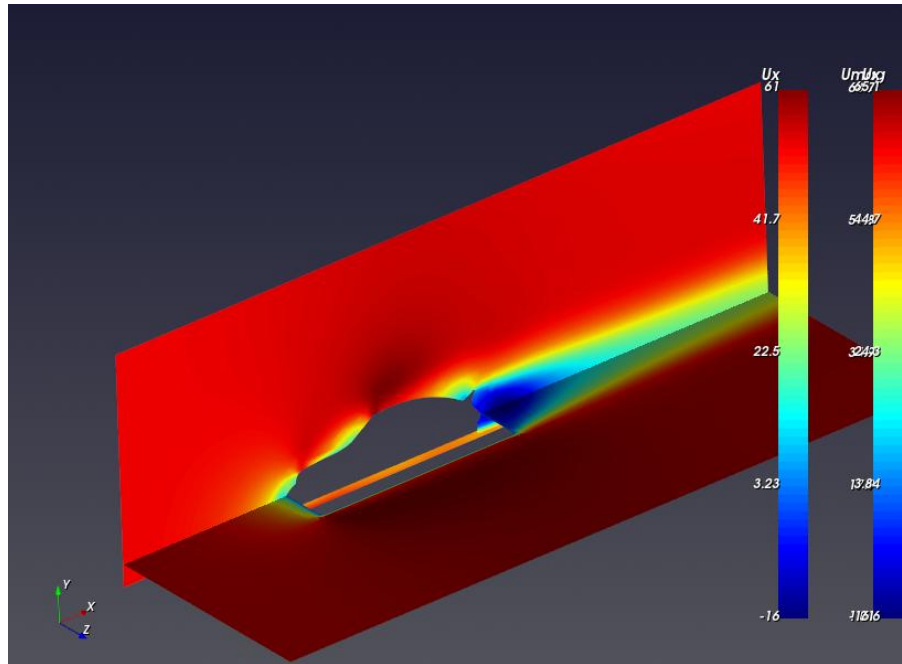

Figure 39. Two velocity contours.

Click **symmetry-center** again and select **U** in the dialog. It will create automatically a vector plot (Figure 40).

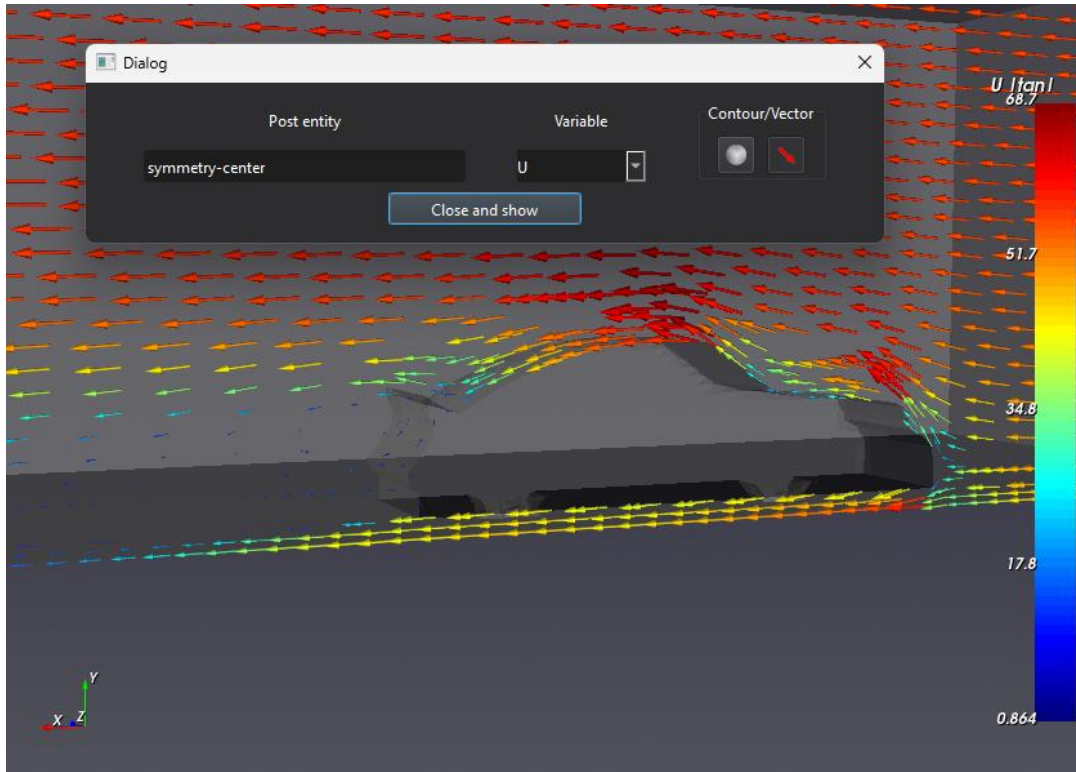

Figure 40. Vector plot on central symmetry plane.

Finally, click **Report** to generate the PDF report.

### 3. Flow in a duct with heated rods (flow with heat transfer)

This case models airflow through a rectangular duct with three heated rods. The duct dimensions are 100 mm (height) × 500 mm (width) × 1500 mm (length). The inlet velocity is 1 m/s and the air is fluid. Start CFXD from the Windows menu or the desktop icon.

#### Geometry

Create the points required to build the geometry. The points coordinates are listed in Table 5. Points Pnt 1, Pnt2 define the duct, and points Pnt3 - Pnt5 define one rod (cylinder). The units are in mm. In the **Input** panel, use **Unit** button to switch to mm before entering coordinates.

*Table 5: Point coordinates (mm).*

<b>Point</b>	<b>Coordinates</b>	<b>Comments</b>
Pnt1	(0, 0, 0)	First corner point of the box
Pnt2	(1500, 400, 100)	Second corner point of the box
Pnt3	(400, 100, 0)	Center point of rod circle
Pnt4	(425, 100, 0)	Radius point (25 mm)
Pnt5	(400, 100, 100)	Height point (100 mm)

The created points are shown in Figure 41.

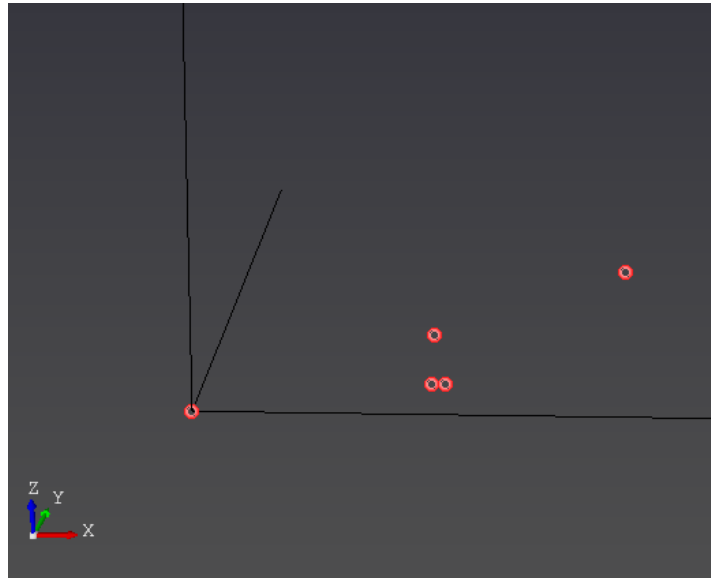



Figure 41. Created points.

Create a cylinder  using Pnt3-Pnt5 (Figure 42).

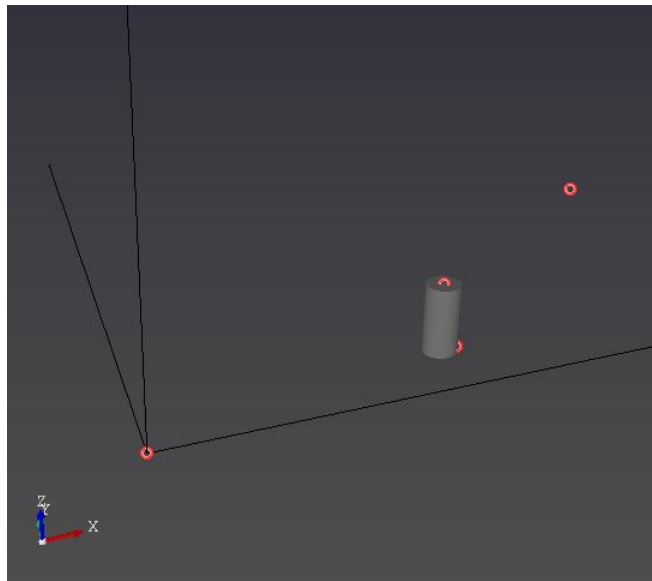

Figure 42. Created cylinder.

Select **Translate** operation, enable **Keep original**, and copy the cylinder to the new positions +100 mm and +200 mm in the Y direction (Figure 43).

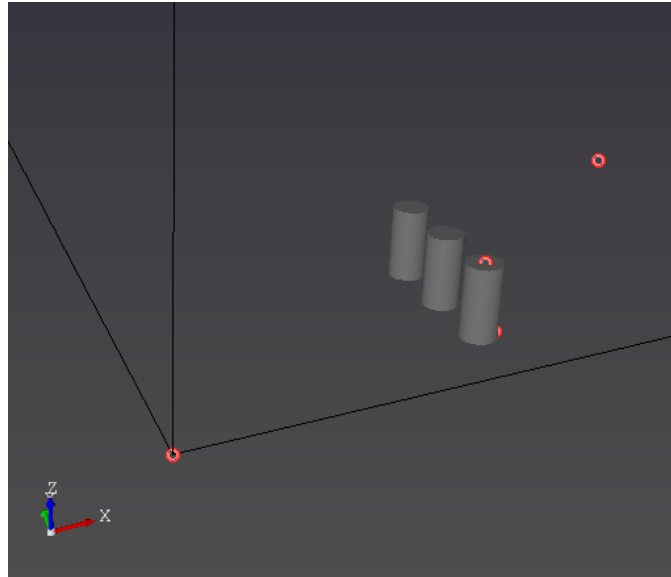

Figure 43. Cylinders created using translation.

Create a box (duct) using Pnt1 and Pnt2, then subtract the three cylinders from the box with unchecked **Keep original** (Figure 44).

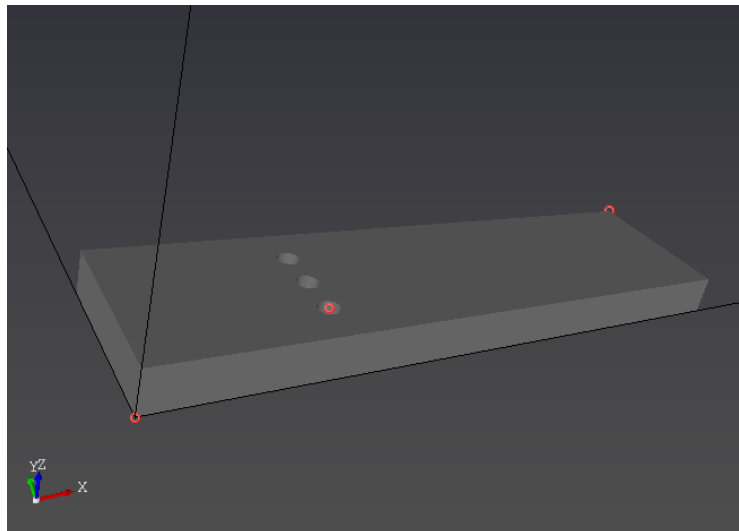

Figure 44. Final body.

Activate **Naming** mode with RMB. Name faces as follows:

- front face: **inlet**
- back face: **outlet**
- two sides: **wall**
- top and bottom: **symmetry**
- cylinders: **wall-hot**.

Use Ctrl+RMB for multi-selection. Releasing of Ctrl opens the naming dialog (Figure 45).

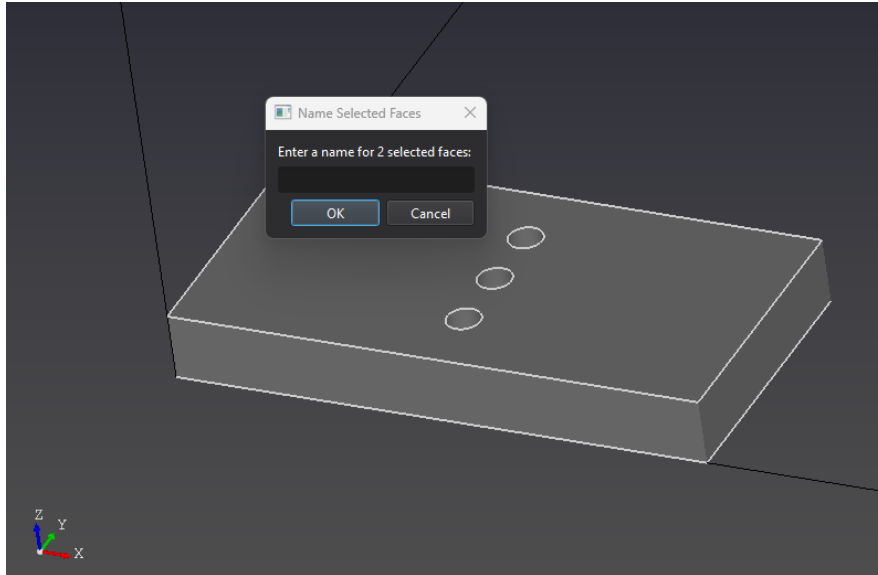

Figure 45. Naming “symmetry” for top and bottom faces.

Click **To mesh** step to proceed.

### Mesh

Keep the default **Cell size**, set **Refinement** level = 1, and enable **Wall treatment**. Click **Generate**. Inspect the mesh with **Mesh cut**. An example cut in Y direction is shown in Figure 46. Also check the mesh quality plots before proceeding.

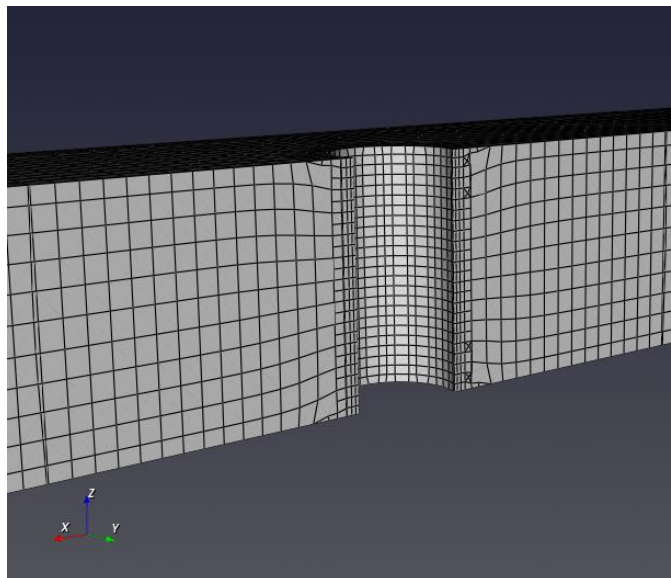

Figure 46. Mesh cut in Y direction.

Click **To Setup**.

## Setup

Keep the default settings for **Fluid model** panel. Enable **Heat transfer** in the **Heat model** panel. Set boundary conditions:

- **inlet**: velocity 2 m/s, temperature 288.15 K
- **outlet**: keep default settings
- **wall** (duct walls): set temperature 350 K
- **wall-hot** (rod walls): set temperature 500 K
- **symmetry**: apply symmetry boundary conditions to faces named symmetry.

The model with set boundary conditions shown in Figure 47.

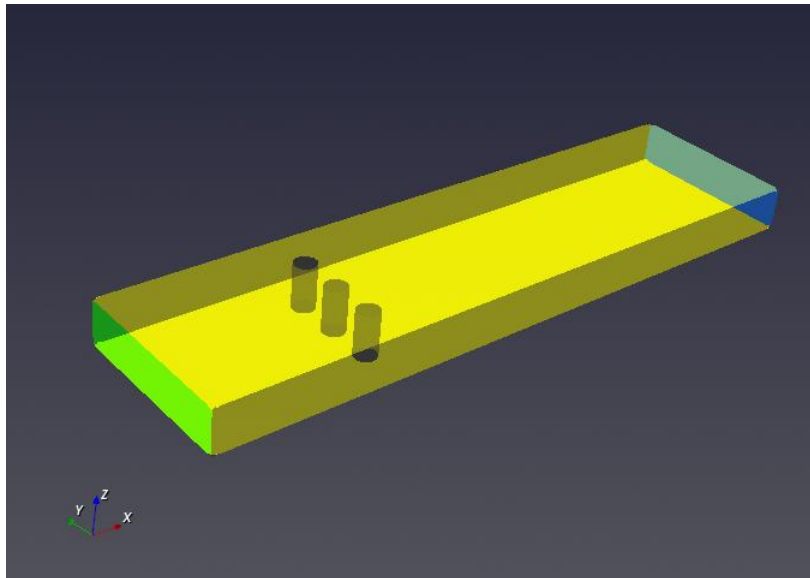

Figure 47. Boundary conditions applied.

Click **To Solution**.

## Solution

Create a monitoring point behind the central rod at (0.46, 0.20, 0.05) and monitor temperature **T**. Run the simulation. The converged solution is shown in Figure 48.

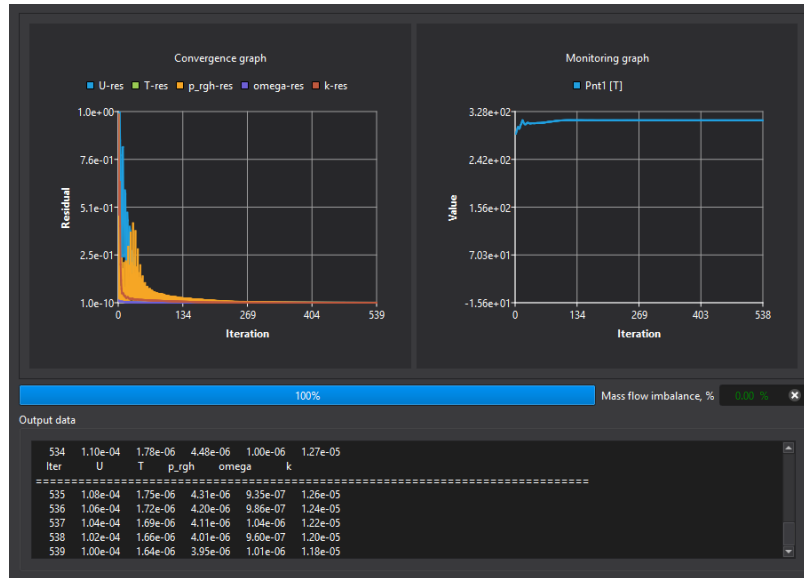

Figure 48. Convergence and monitoring graphs.

Click To Result.

## Result

Create two planes at  $Y = 0.2$  m and  $Z = 0.05$  m and visualize the temperature fields on both planes (Figure 49).

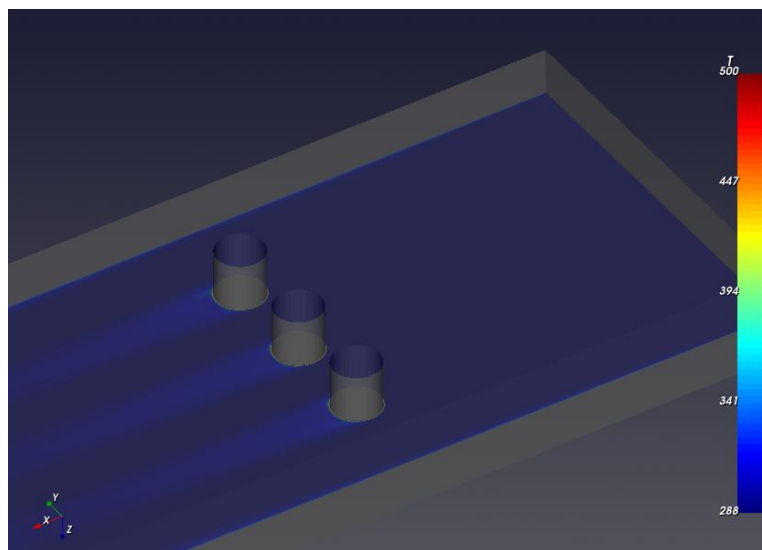

Figure 49. Temperature fields at center horizontal and vertical plane.

On the horizontal plane, visualize **velocity magnitude** and add a **vector plot** to observe separation behind the rods (Figure 50).

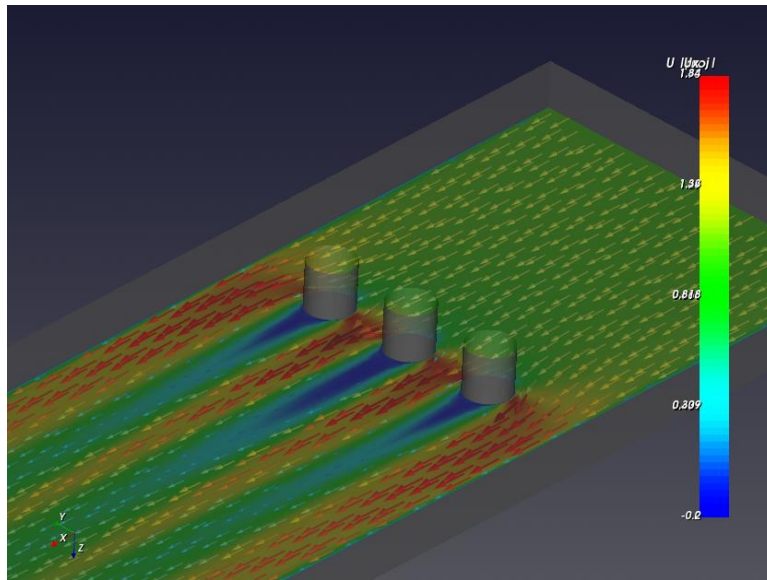

Figure 50. Velocity and vector plot on horizontal plane.

Finally, click **Report** to generate the PDF report.

#### 4. Natural convection in a closed box (buoyancy-driven flow)

This case models natural convection in a closed box. The box dimensions are 200 mm (height) × 500 mm (width) × 500 mm (length). A rectangular heat source is located at the center of the box floor. The heat source dimensions are 10 mm (height) × 50 mm (width) × 50 mm (length). Start CFXD from the Windows menu or the desktop icon.

##### Geometry

Create the points required to build the geometry. The points coordinates are listed in Table 6. Points Pnt1 and Pnt2 define the box. Points Pnt3 and Pnt4 define the heat source. The units are in mm. In the **Input** panel, use **Unit** button to switch to mm before entering coordinates.

Table 6: Point coordinates (mm).

Point	Coordinates	Comments
Pnt1	(0, 0, 0)	First corner point of the box 1
Pnt2	(200, 500, 500)	Second corner point of the box 1
Pnt3	(0, 200, 200)	First corner point of the box 2
Pnt4	(10, 250, 250)	Second corner point of the box 2

The created points are shown in Figure 51.

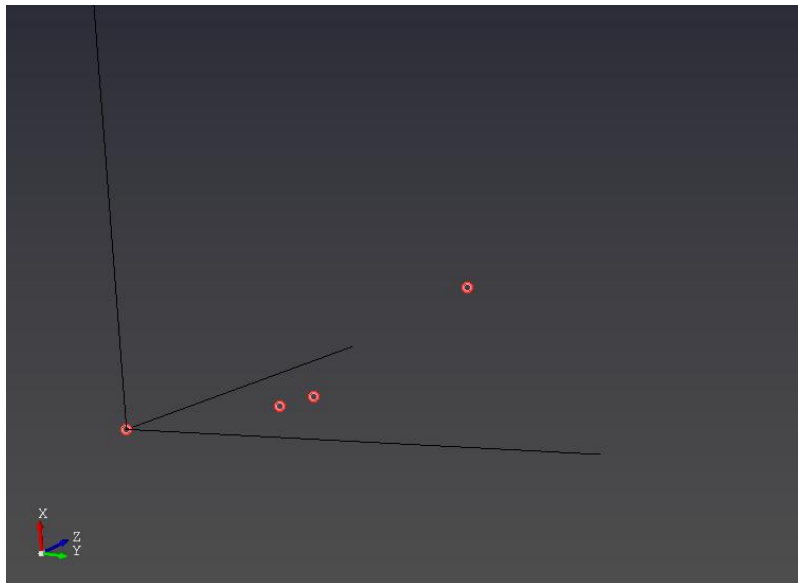



Figure 51. Created points.

Create small and large boxes with Box  tool (Figure 52).

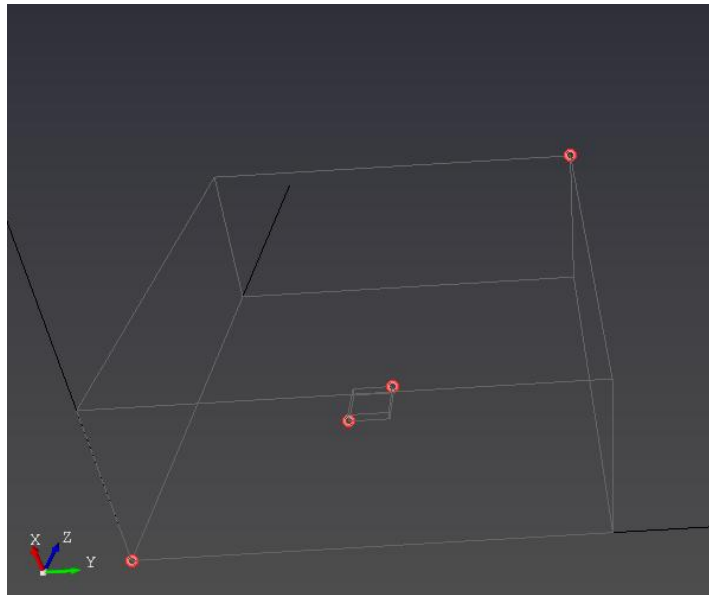



Figure 52. Two boxes.

Extract small box from the large one with Subtract  tool. The new Body3 (volume) will be formed (Figure 53).

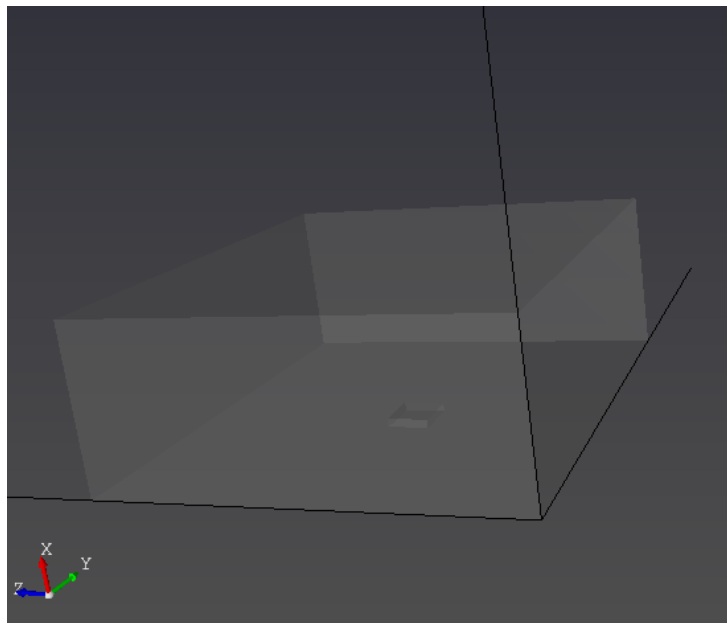
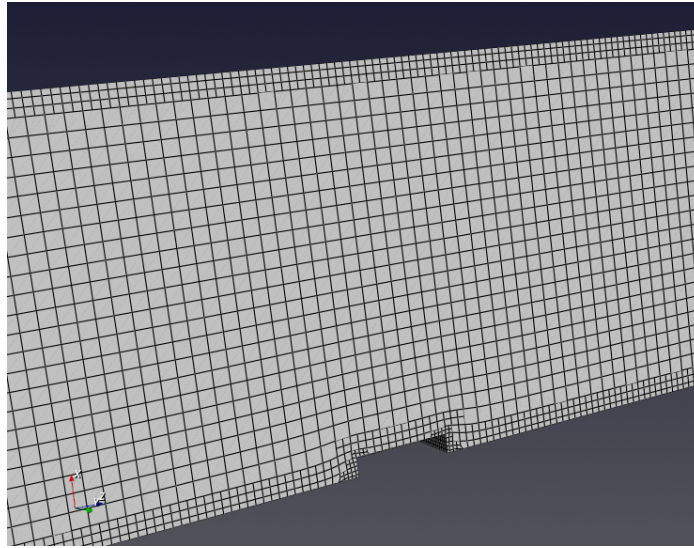

Figure 53. Volume for the simulation.

Add the following names: wall-hot for the heat source and wall-ambient for all other walls. Use Ctrl+RMB for multi-selection. Click **To mesh** step to proceed.

## Mesh

Keep the default **Cell size** and set **Refinement level = 2**. Click **Generate**. Inspect the mesh with a cut. Also check the mesh quality plots before proceeding. The generated mesh (cut view) is shown in Figure 54.



*Figure 54. The generated mesh (cut view).*

Click **To Setup**.

## Setup

Keep the default settings for **Fluid model** panel. Enable **Heat transfer** in the **Heat model** panel. Set temperature 450K for wall-hot and 288.15K for wall-ambient Figure 55.

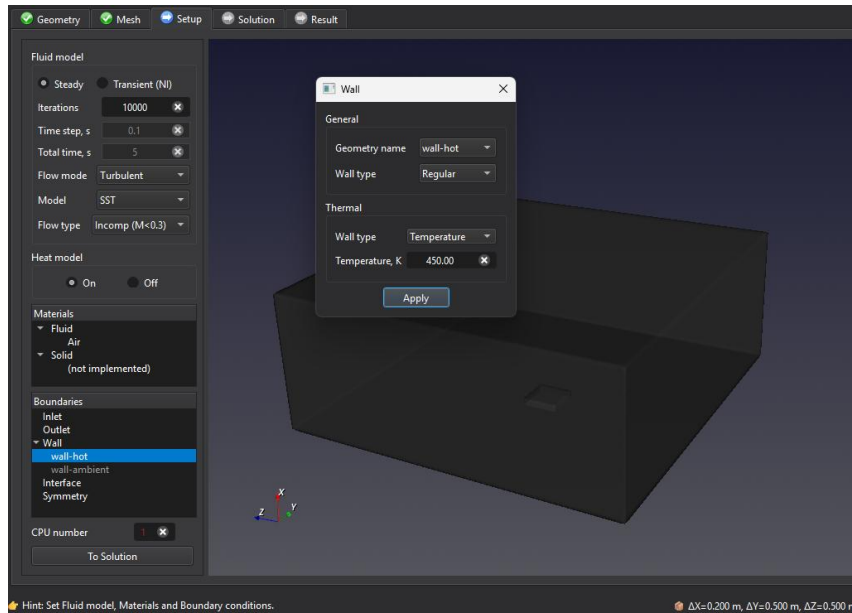

Figure 55. Boundary conditions.

This case does not have inlet and outlet. In the top menu in Settings select the Operating Conditions, enable Buoyancy, keep the default Reference pressure and temperature and set a Gravitational Acceleration in x direction Figure 56.

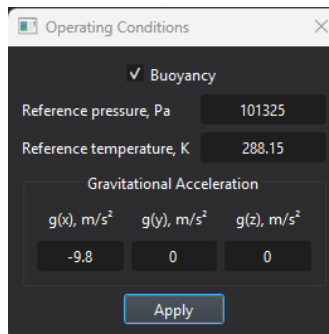

Figure 56. Enable buoyancy.

Click **To Solution**.

### Solution

Create a monitoring point above the heat source at (0.200, 0.225, 0.225) and monitor temperature **T**. **Run** the simulation. The converged solution is shown in Figure 57

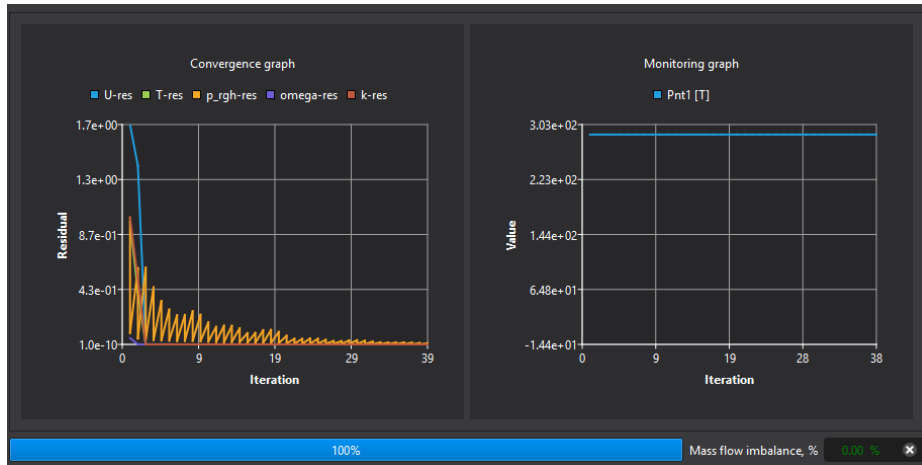

Figure 57. Converged solution for closed box.

Click **To Result** to move to the next stage.

## Result

Create a XZ plane at center  $Y=0.225\text{m}$  in **Post entities** panel and visualize a vector plot U (Figure 58).

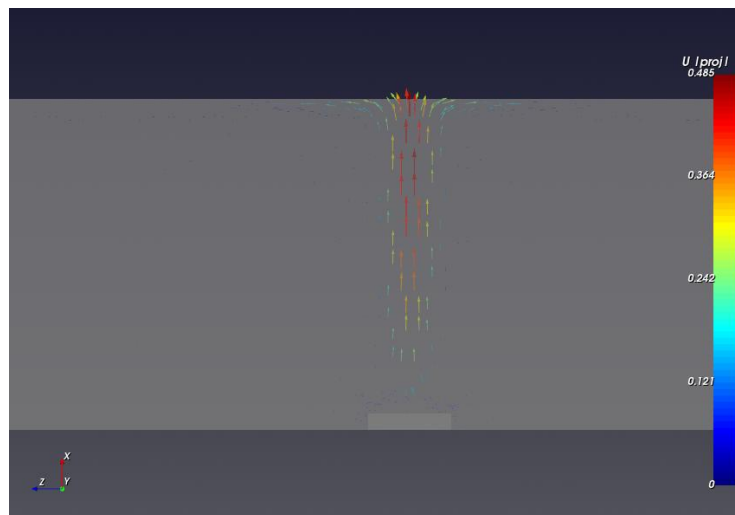

Figure 58. Vector plot on XZ plane at  $Y=0.225$ .

Click **Report** to generate the PDF report.

## 5. Free jet in open air (compressible subsonic flow, $M < 1$ )

The case represents a free round jet with diameter  $D = 1.0$  m discharging into open air. The jet exit velocity is 300 m/s, while the surrounding (coflow) air velocity is 10 m/s. The jet temperature is 700 K and the surrounding air temperature is 288.15 K (standard ambient). The jet Mach number can be calculated as

$$M = \frac{u}{a} = \frac{u}{\sqrt{kRT}} = \frac{300}{\sqrt{1.4 \cdot 287 \cdot 700}} = 0.57.$$

Since  $M > 0.3$  [1], compressibility effects should be considered.

### Geometry

Since the round jet is axisymmetric only a quarter of the configuration will be modelled. The points required to construct the geometry are listed in Table 7 (units: m). Points Pnt1 – Pnt3 define the jet, and points Pnt4 – Pnt6 define the surrounding open-air domain.

Table 7: Point coordinates.

Point	Coordinates	Comments
Pnt1	(0, 0, 0)	Center point of quarter of first circle
Pnt2	(0, 0.5, 0)	Radius point of quarter of first circle
Pnt3	(0, 0, 0.5)	Radius point of quarter of first circle
Pnt4	(5, 0, 0)	Center point of quarter of second circle
Pnt5	(5, 0.5, 0)	Radius point of quarter of second circle
Pnt6	(5, 0, 0.5)	Radius point of quarter of second circle

The created points are shown in Figure 59.

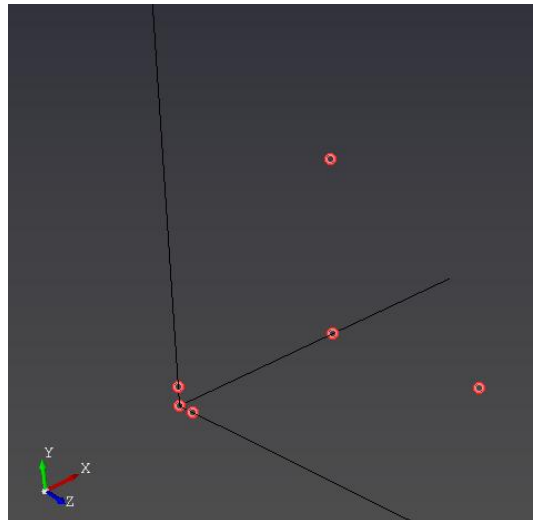

Figure 59. Created points.

Create lines and arc as shown in Figure 60.

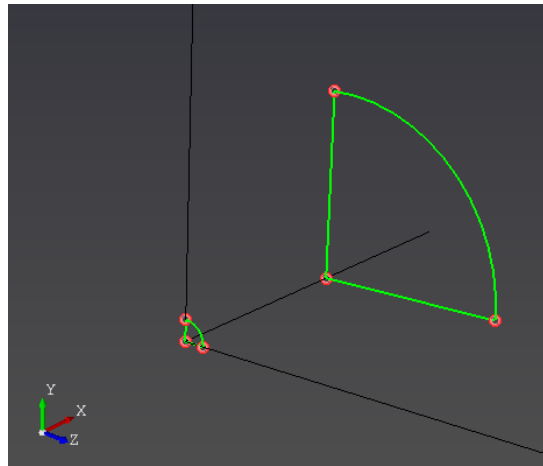



Figure 60. Lines and arcs required for surface creation.

Use **Edge-Surface** creation tool  to generate surfaces by selecting three edges. After the surfaces are created, pull the first (small) surface by 5 m and the second (large) surface by 15 m in the X-direction (Figure 61). During the pull operation, the yellow guide line indicates the extrusion direction. In the example, it points in the -X direction, therefore, to extrude in the +X direction, a negative value must be entered (-15) in the input panel.

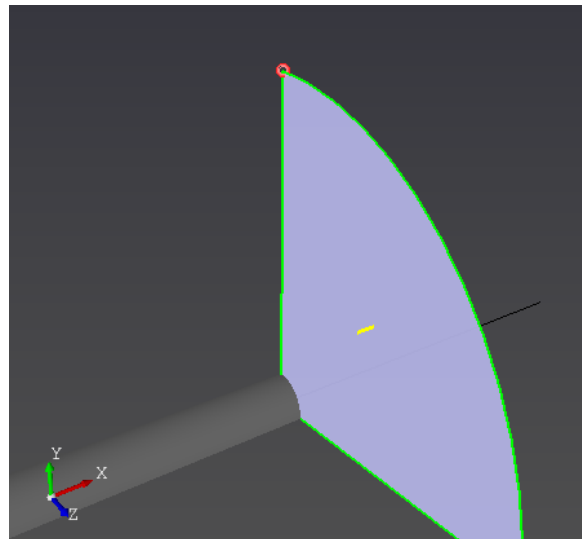

Figure 61. Pull a sector of circle.

Use a Boolean unite operation to combine two bodies. After combining, set the names for faces as shown in Figure 62.

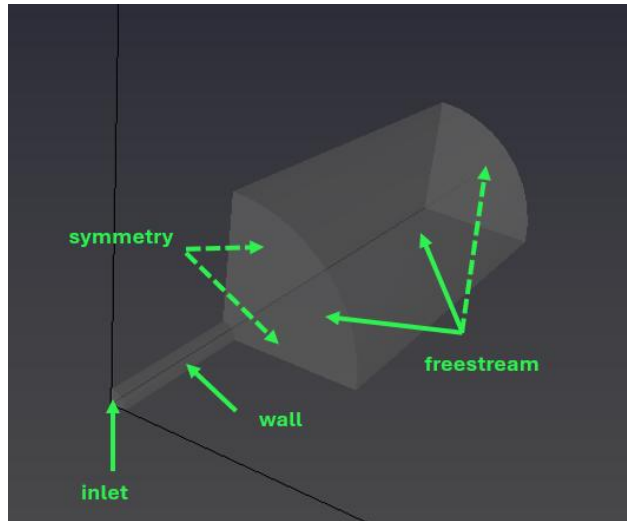

Figure 62. Naming of faces.

Click **To mesh** step to proceed.

### Mesh

Keep the default **Cell size** and set **Refinement** level = 2. Click **Generate**. Inspect the mesh with rotation. Also check the mesh quality plots before proceeding. The generated mesh is shown in Figure 63.

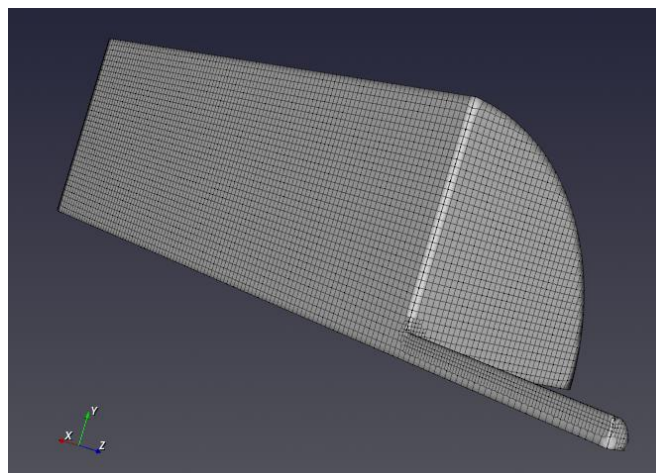

Figure 63. Generated mesh.

Click **To Setup** to move to the next stage.

### Setup

In **Fluid model** panel change default SST model to k-eps model. k-eps model is more suitable for free jet. Select **Comp (M<1)** in the **Flow type**. It will automatically activate **Heat transfer** in

the **Heat model** panel as the compressible flow modeling requires the energy equation. Set the following boundary conditions:

- **inlet:** velocity 300 m/s, temperature 700 K, turbulent intensity 5%, length scale 0.5 m,
- **freestream:** velocity 10 m/s, temperature 288.15 K, turbulent intensity 1%, length scale 5 m.
- **wall:** set adiabatic
- **symmetry:** apply symmetry boundary conditions to faces named symmetry.

The model with set boundary conditions is shown in Figure 64.

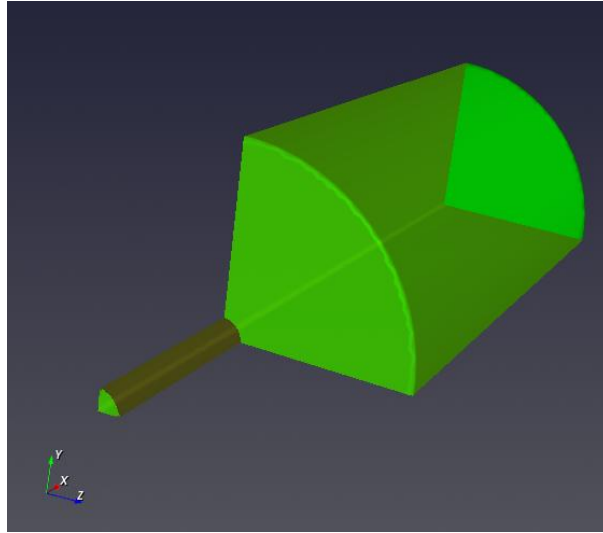

*Figure 64. Boundary conditions applied.*

Click **To Solution** to move to the next stage.

### **Solution**

Add a monitoring point at 5 m from the jet exit at (10, 0, 0) and select  $U_x$  velocity as monitoring variable. Run the simulation. The convergence and monitoring graphs are shown in Figure 65.

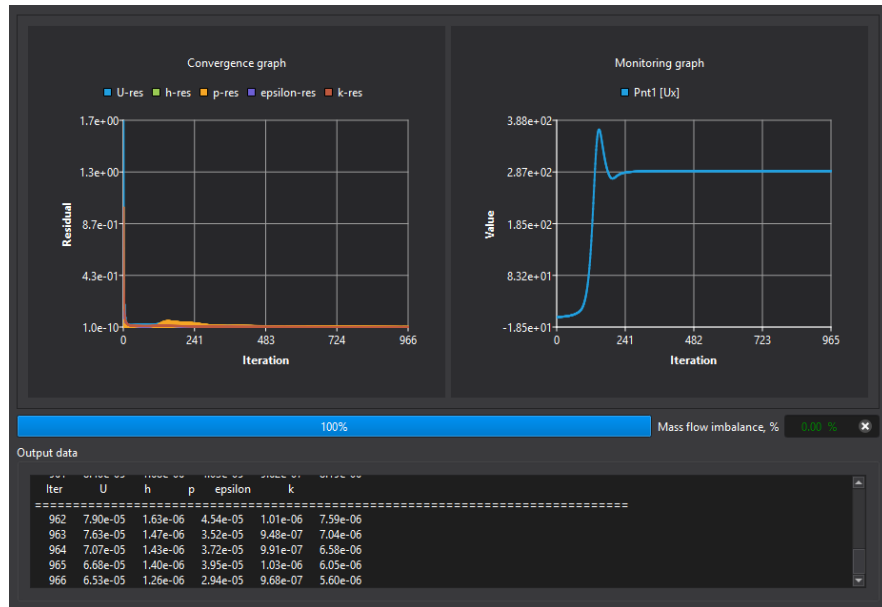

Figure 65. Convergence and monitoring graphs.

Click **To Result** to move to the next stage.

## Result

Click on symmetry in **Post entities** panel and visualize  $U_{mag}$  (Figure 66).

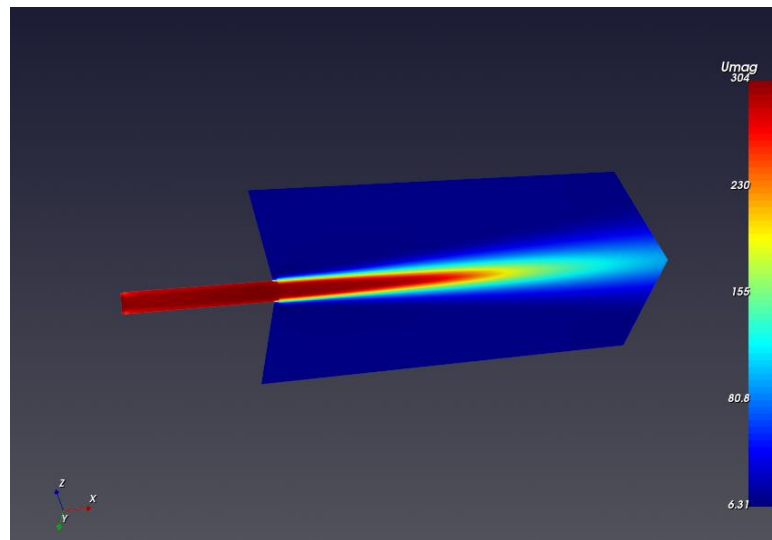

Figure 66. Absolute velocity contour on symmetry planes.

Create a post line with two points (10,0,0) and (10,5,0) and generate a chart for the temperature Figure 67.

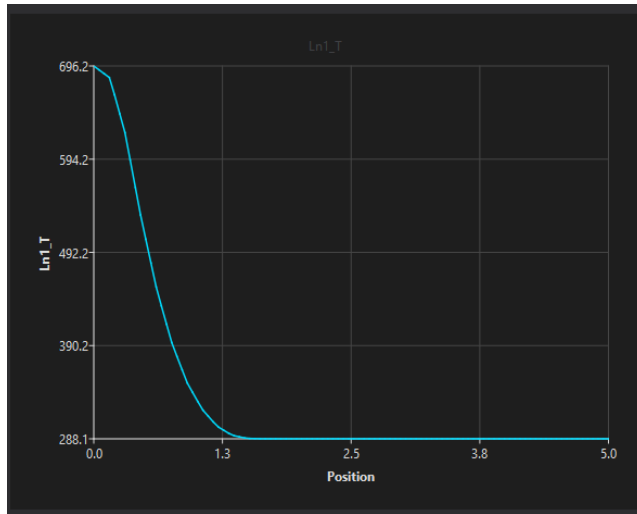

Figure 67. Temperature chart at 5m from jet exit.

Click **Report** to generate the PDF report.

## 6. Flow in a pipe with a butterfly valve (thin internal wall)

This case represents flow in a cylindrical pipe with diameter  $D = 1.0$  m, containing a butterfly valve positioned at  $45^\circ$ . The fluid is water.

### Geometry

The points required to construct the cylinder geometry, and the thin butterfly valve disk are listed below (units: m). Points **Pnt1–Pnt3** define the cylinder, and points **Pnt1**, **Pnt2** and **Pnt4** define the disk.

Table 8: Point coordinates.

Point	Coordinates	Comments
Pnt1	(0, 0, 0)	Center point of cylinder base
Pnt2	(0, 0.5, 0)	Radius point of cylinder base
Pnt3	(10, 0, 0)	Height point of cylinder
Pnt4	(0, 0, 0.5)	Radius point of circle

The created points are shown in Figure 68.

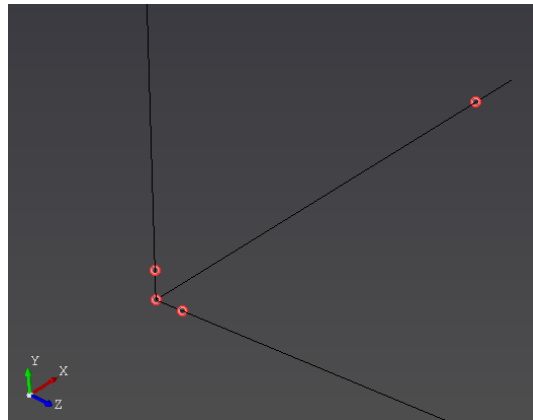

Figure 68. Created points.

Create a cylinder, a circle, then create a surface based on the circle (Figure 69).

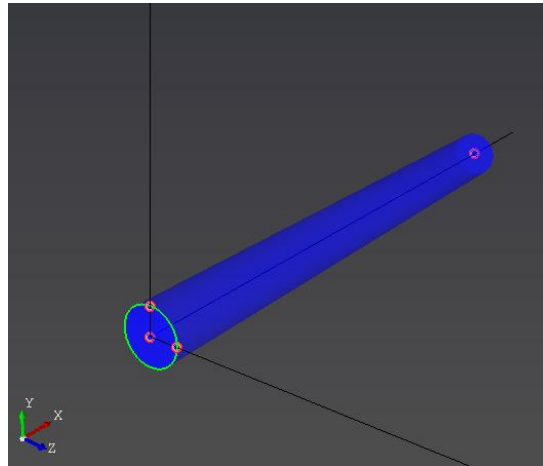

Figure 69. Cylinder, circle and surface.

Select the surface, apply a **45° rotation about the Z-axis**, and move it to **x = 4 m** (Figure 70).

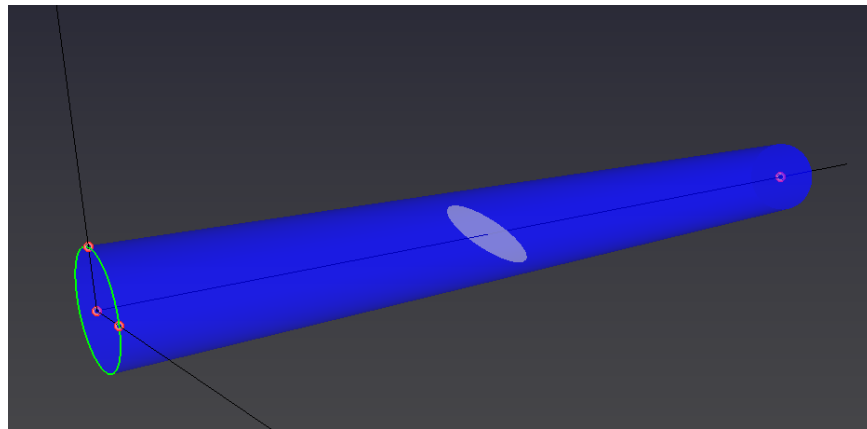

Figure 70. Valve at 4 m from inlet.

Name the front face **inlet**, the back face **outlet**, and the internal surface **valve**. Click **To Mesh** to switch to the **Mesh** stage.

### Mesh

Keep the default **Cell size** and click **Surface** to set a local refinement. Select **valve**, set the local size as **0.02** (Figure 71). Apply the settings and close the **Surface refinement** dialog.

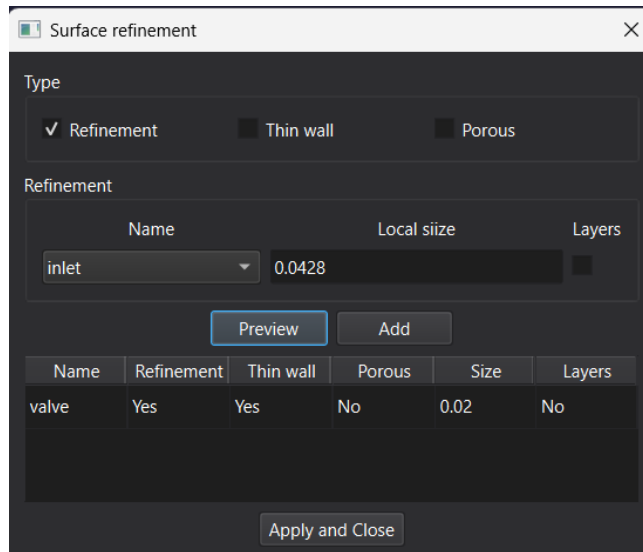

Figure 71. Refinement settings for valve surface.

Click **Generate**. Inspect the mesh and review the mesh quality plots before proceeding. Use **Cut section** to examine the mesh around the valve (Figure 72). Click **To Setup** to move to the next stage.

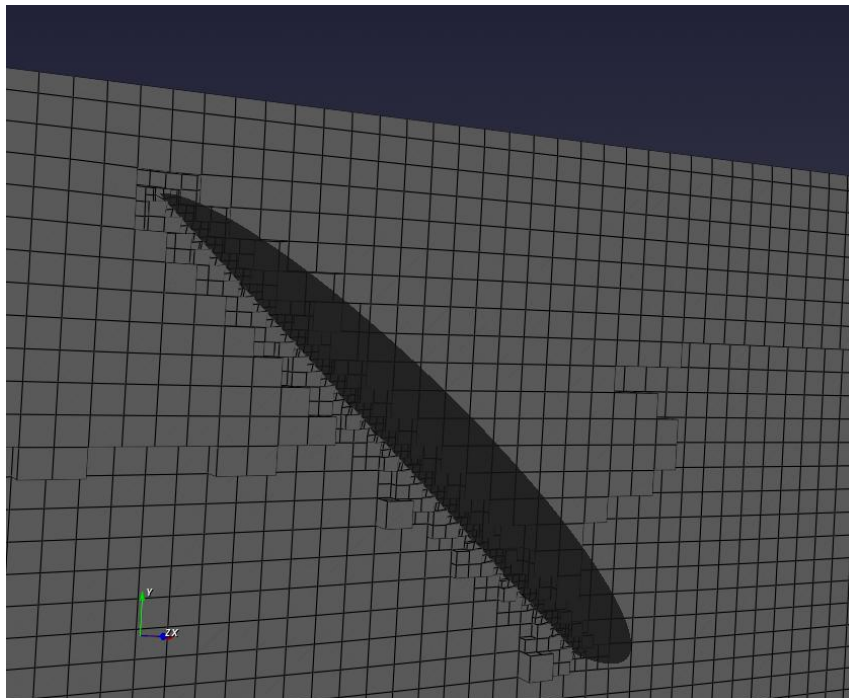

Figure 72. Mesh around the valve.

## Setup

In the **Fluid model** panel, set the turbulence model to **k-eps** and the flow type to **Incomp (M < 0.3)**. Set the fluid material to **Water**.

Apply the following boundary conditions (Figure 73):

- **Inlet** → inlet: velocity 5 m/s, turbulent intensity 5%, length scale 1.0 m,
- **Outlet** → outlet: pressure 0 Pa,
- **Wall** → wall: regular,
- **Interface** → valve: wall, regular.

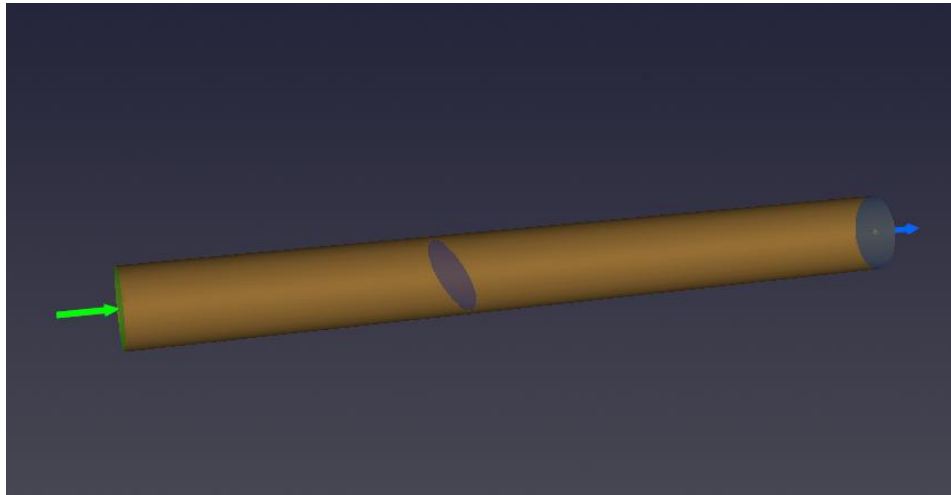

Figure 73. Boundary conditions applied.

Click **To Solution** to move to the next stage.

### Solution

Add a monitoring point at 5 m (5, 0, 0) from the **inlet** and select **Ux velocity** as monitoring variable. Run the simulation. The convergence and monitoring graphs are shown in Figure 74.

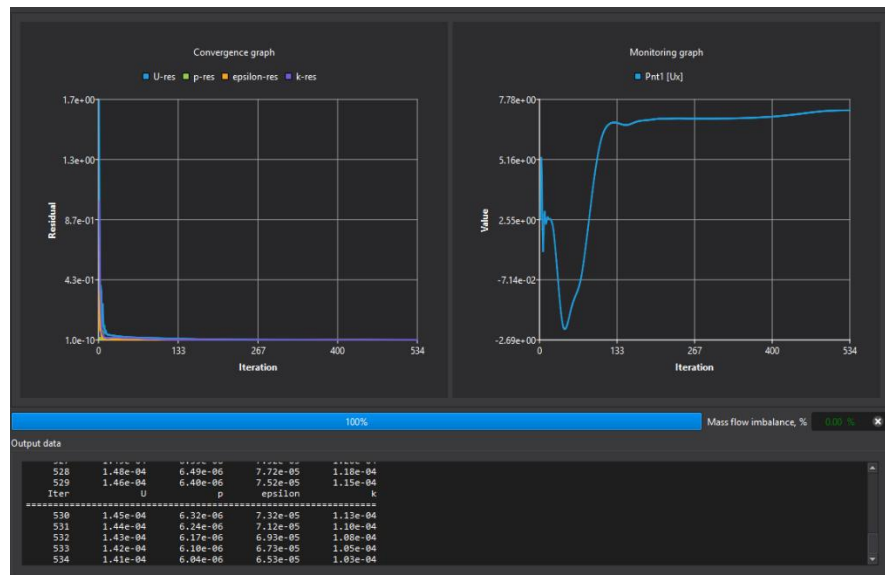

Figure 74. Convergence and monitoring graphs.

Click **To Result** to move to the next stage.

## Result

Create a default plane (XY) in **Post entities** panel and visualize Velocity magnitude ( $|U|$ ) (Figure 75).

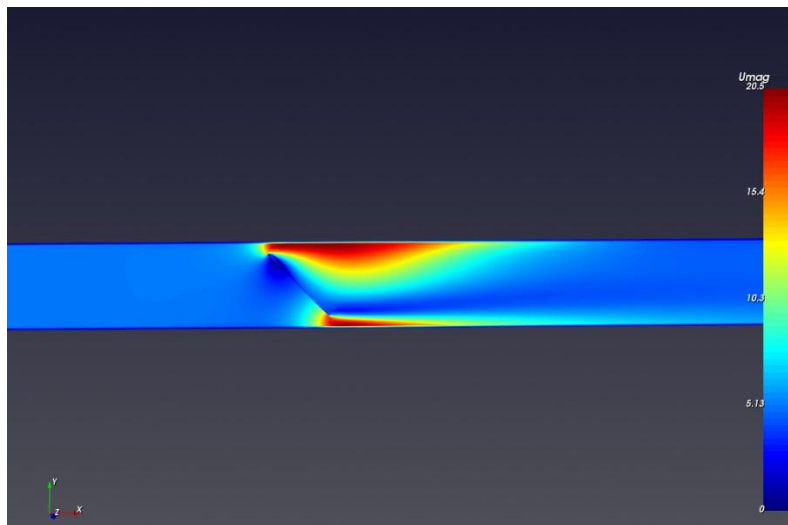

Figure 75. Velocity magnitude contour on the XY plane.

Visualize gauge pressure on the same plane (Figure 76).

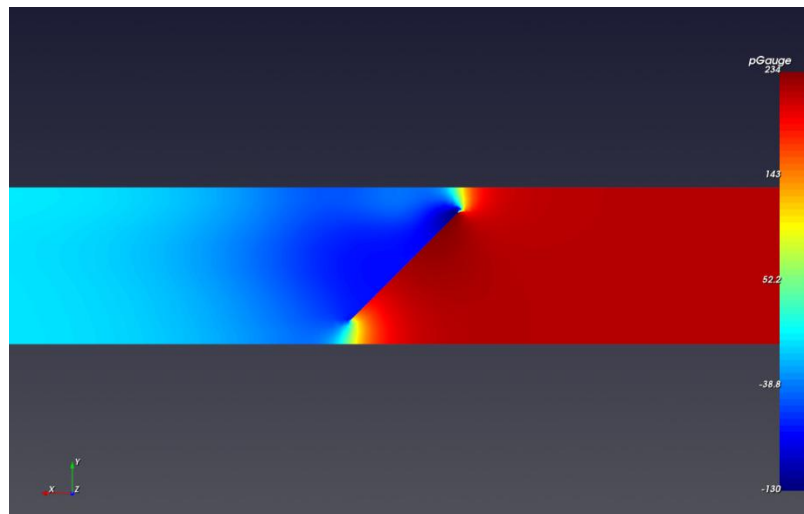

Figure 76. Gauge pressure on XY plane.

Click **Report** to generate the PDF report.

## 7. Flow in a settling chamber (porous media)

This case models airflow in a test rig used for aerodynamical measurements. The system consists of a pipe with diameter  $D = 100 \text{ mm}$  including a  $90^\circ$  bend, a diffuser and a settling chamber with diameter  $D = 300 \text{ mm}$ . A mesh and perforated plate are installed in the settling chamber to reduce flow distortion generated by the bend. The pressure loss coefficients are  $\zeta = 3$  for the mesh and  $\zeta = 5$  for perforated plat. The mesh thickness is negligible, while the perforated plate thickness is  $D = 50 \text{ mm}$ .

### Geometry

The points required to construct the configuration are listed below (units: mm). Points **Pnt1–Pnt3** define the circle, **Pnt3-Pn4** define the first line, **Pnt4-Pnt6** define the arc, Pnt6-Pnt7 define the second line, **Pnt7-Pnt10** used for cone, and **Pnt9-Pn11** for cylinder.

Table 9: Point coordinates.

Point	Coordinates	Comments
Pnt1	(0, 0, 0)	Center point of circle
Pnt2	(0, 50, 0)	Radius point of circle
Pnt3	(0, 0, 50)	Radius point of circle
Pnt4	(200, 100, 0)	Center point of arc
Pnt5	(200, 0, 0)	Radius point of arc
Pnt6	(300, 100, 0)	Radius point of arc
Pnt7	(300, 300, 0)	Center of cone base 1
Pnt8	(350, 300, 0)	Radius of cone base 1
Pnt9	(300, 400, 0)	Center of cone base 2
Pnt10	(450, 400, 0)	Radius of cone base 2
Pnt11	(300, 1400,0)	End point of cylinder

The created points are shown in Figure 77.

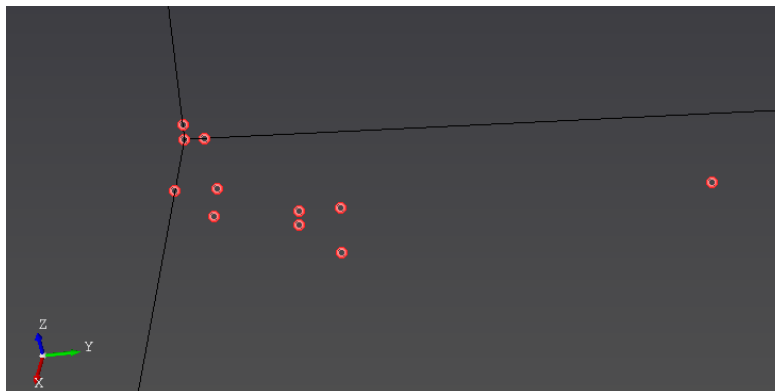
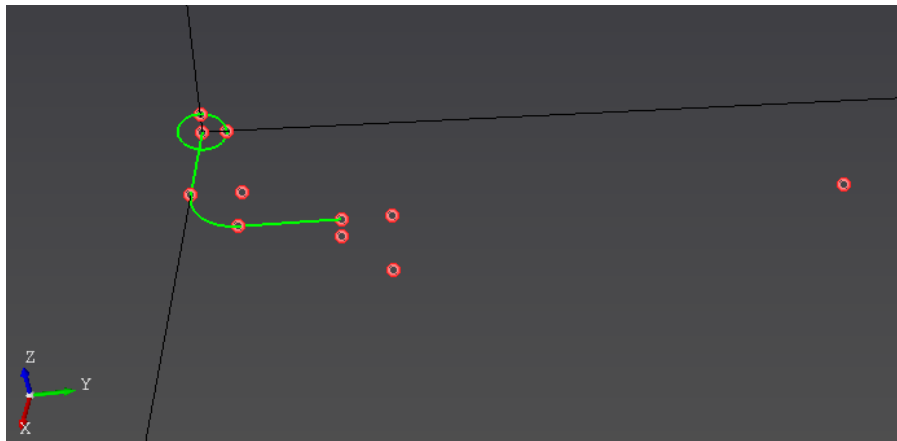

Figure 77. Created points.

Create a circle, and three curve segments as shown in Figure 78.



*Figure 78. Cylinder, two lines and arc.*

Create a surface with circle and pull it along line-arc-line (Figure 79).

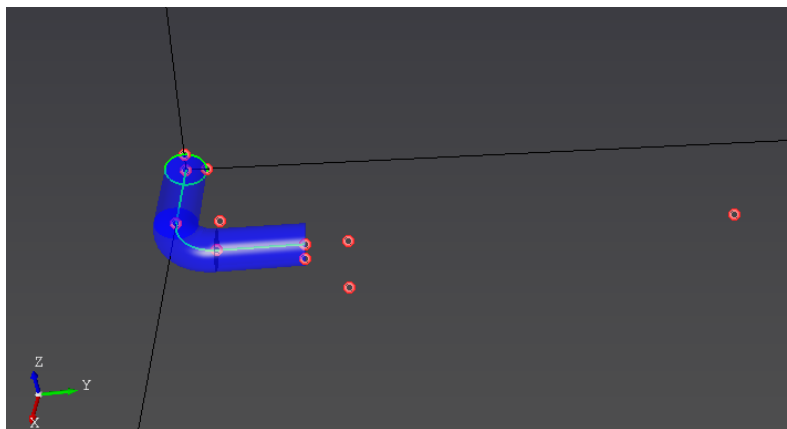

*Figure 79. Circle pull.*

Create a cone using points Pnt7-Pnt10 and cylinder using points Pnt9-Pnt11. Use the Boolean unite operation to create a single body (Figure 80).

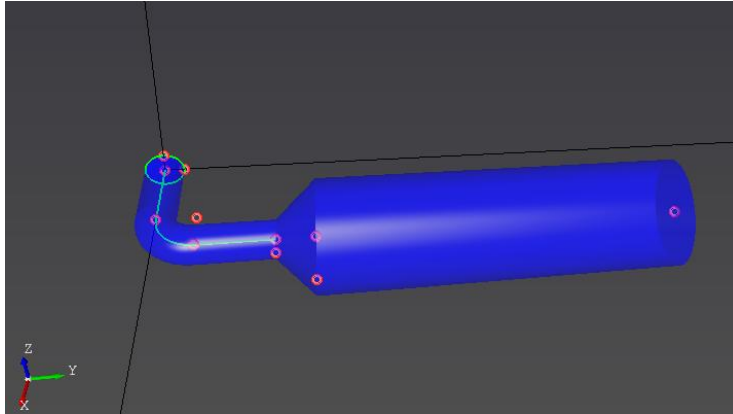

Figure 80. Body geometry.

Add three additional points to create the internal surface that will be used for porous jump model (Table 10).

Table 10: Points for the internal surface.

Pnt12	(300, 500, 0)	Center of circle
Pnt13	(450, 500, 0)	Radius of circle
Pnt14	(300, 500, 150)	Radius of circle

Create a circle using points Pnt12-Pnt14 and make an internal surface. The final geometry is shown in Figure 81.

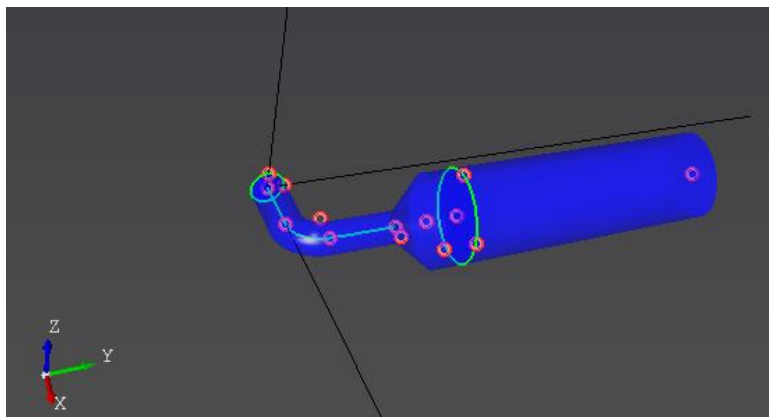

Figure 81. Final geometry.

Name the inlet face **inlet**, the outlet face **outlet**, and the internal surface **por-jump**. Use the **Hide** option to select the internal surface. Click **To Mesh** to switch to the **Mesh** stage.

### Mesh

Keep the default **Cell size** and click **Surface** to set a local refinement for the internal surface. Select **por-jump**, keep the **Local size** at the default value (**0.098**) (Figure 82). In general, using the

same **Local size** as the global **Cell size** does not apply any additional refinement. Apply the settings and close the **Surface refinement** dialog.

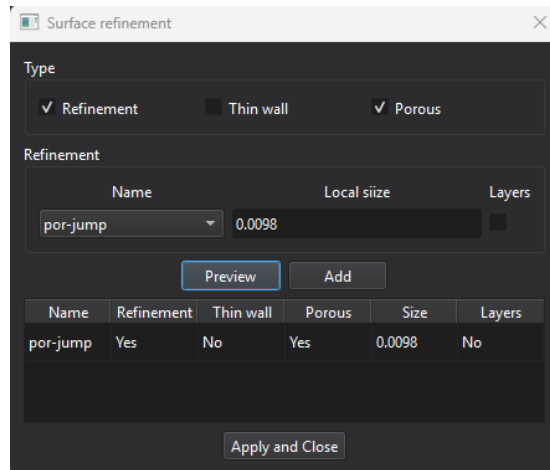

Figure 82. Setup of internal surface as porous jump.

Click **Volume** to create a porous zone. Select **Porous** and **Box**, then enter the diagonal points of the box: (0.1, 0.55, -0.2) and (0.5, 0.6, 0.2). Keep the default local size (no additional refinement is applied). Click **Add to List**, then **Apply and Close** (Figure 83). The volume inside the box will be marked as a porous zone.

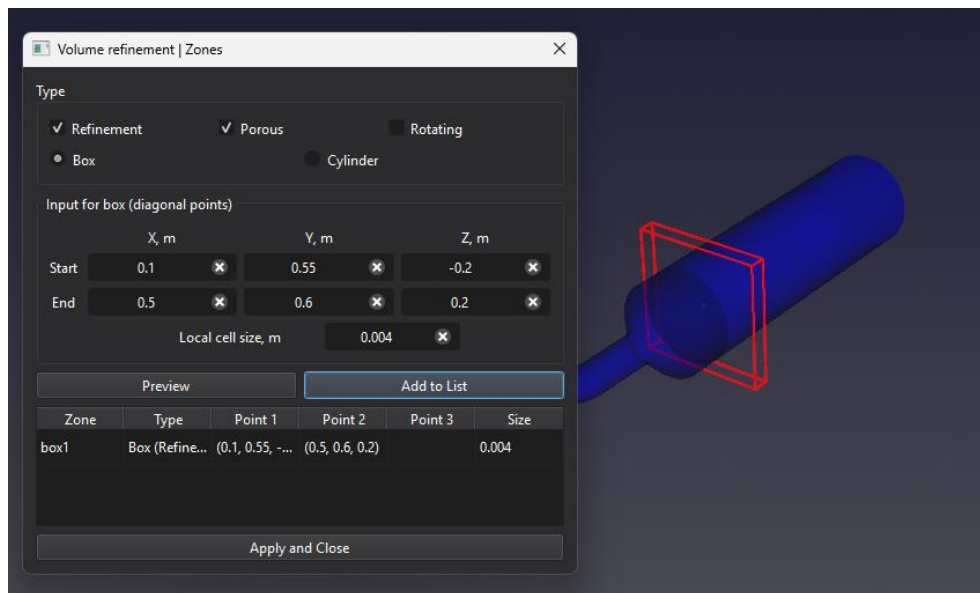

Figure 83. Porous zone definition.

Click **Generate**. Inspect the mesh and review the mesh quality plots before proceeding. Use **Cut section** to examine the mesh around the porous region (Figure 84). Click **To Setup** to move to the next stage.

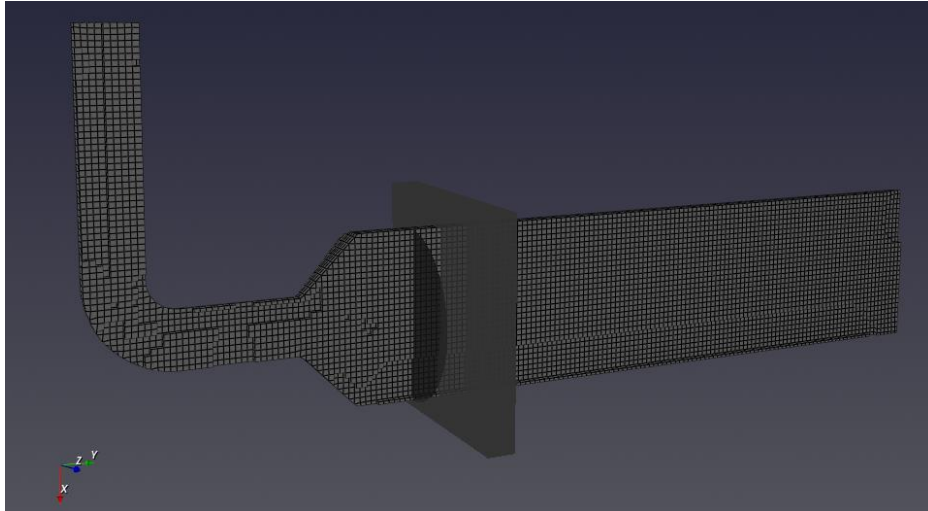

Figure 84. Generated mesh.

### Setup

In the **Fluid model** panel, set the turbulence model to **k-eps** and the flow type to **Incomp (M < 0.3)**. Use the default fluid material to **Air**.

In the **Domains** tree, select **box1** under Porous. In the **Porous zone** dialog, set the length to 0.05 m and set the directional loss coefficients to x: 100, y: 5, z:100.

Apply the following boundary conditions (Figure 85):

- **Inlet** → inlet: velocity 5 m/s (x direction), turbulent intensity 5%, length scale 0.1 m,
- **Outlet** → outlet: pressure 0 Pa,
- **Wall** → wall: regular,
- **Interface** → por-jump: Porous, loss coefficient 3.

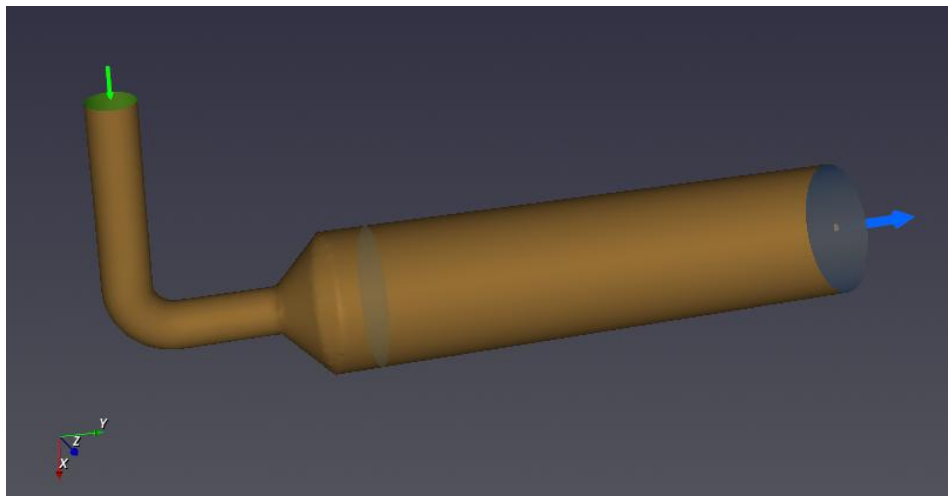

Figure 85. Boundary conditions applied.

Click **To Solution** to move to the next stage.

## Solution

Add a monitoring point at 0.1 m downstream of the porous zone at (0.3, 0.6, 0) and select **Umag velocity** as monitoring variable. Run the simulation. The convergence and monitoring graphs are shown in Figure 86.

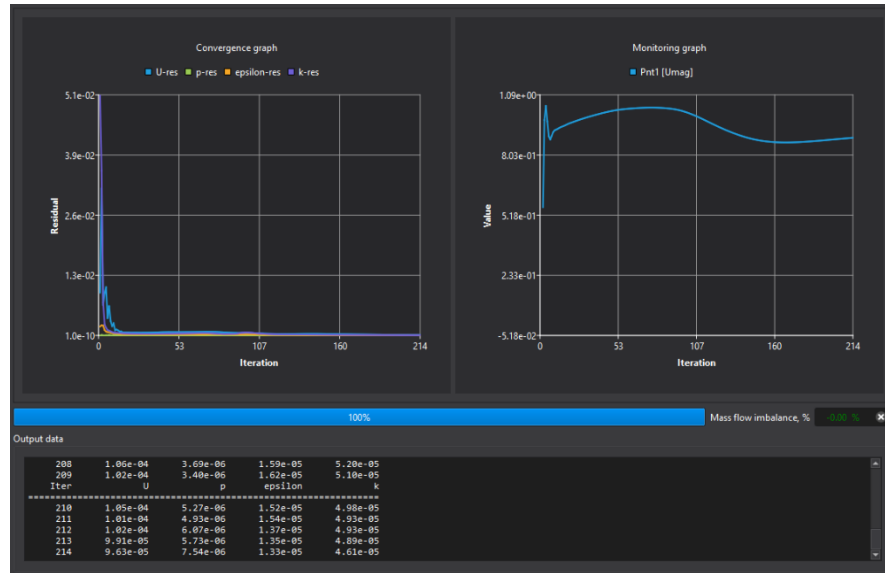

Figure 86. Convergence and monitoring graphs.

Click **To Result** to move to the next stage.

## Result

Create a default plane (XY) in **Post entities** panel and visualize Velocity magnitude ( $|U|$ ) (Figure 87).

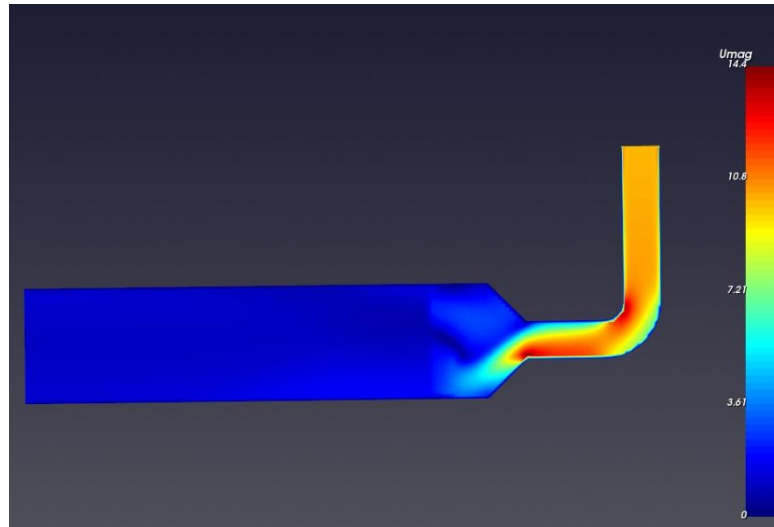

Figure 87. Velocity magnitude contour on the XY plane.

Visualize **gauge pressure** on the same plane (Figure 88).

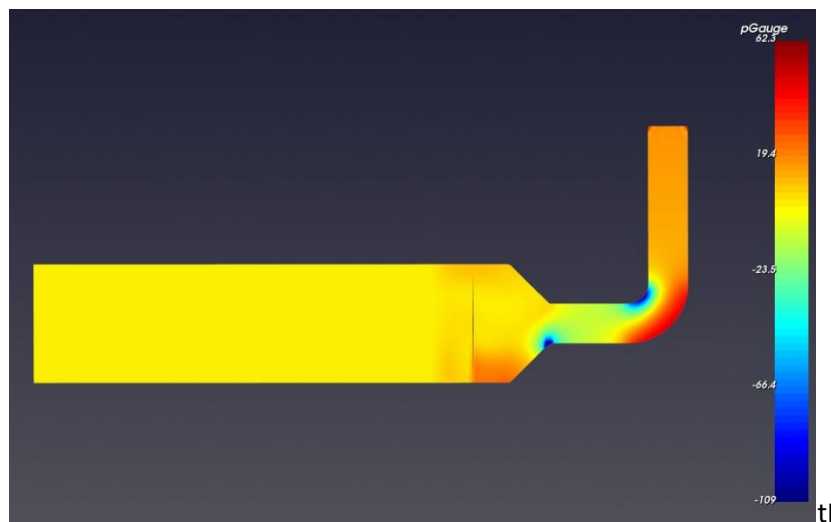

Figure 88. Gauge pressure on XY plane.

Click **Report** to generate the PDF report.

## 8. Transient flow around a cylinder (laminar vortex shedding)

This case models a laminar flow around a cylinder. The cylinder diameter is  $D = 10 \text{ mm}$ . The inlet velocity is  $U = 1.20 \text{ m/s}$ . For air, the corresponding Reynolds number is approximately  $Re = 800$ .

### Geometry

Five points required to construct the cylinder and surrounding box. The points coordinates are listed in Table 11 (units: mm). Points **Pnt1–Pnt3** define the cylinder, **Pnt4–Pnt5** define the box.

Table 11: Point coordinates.

Point	Coordinates	Comments
Pnt1	(0, 0, 0)	Center point of cylinder base
Pnt2	(5, 0, 0)	Radius point of cylinder base
Pnt3	(0, 0, 10)	Height point of cylinder
Pnt4	(-100, -110, 0)	First corner point of the box
Pnt5	(250, 100, 10)	Second corner point of the box

Create the five points, then create a cylinder and a box. Use the Subtract operation to remove the cylinder volume from the box.. The created cylinder and surrounding box are shown in Figure 89.

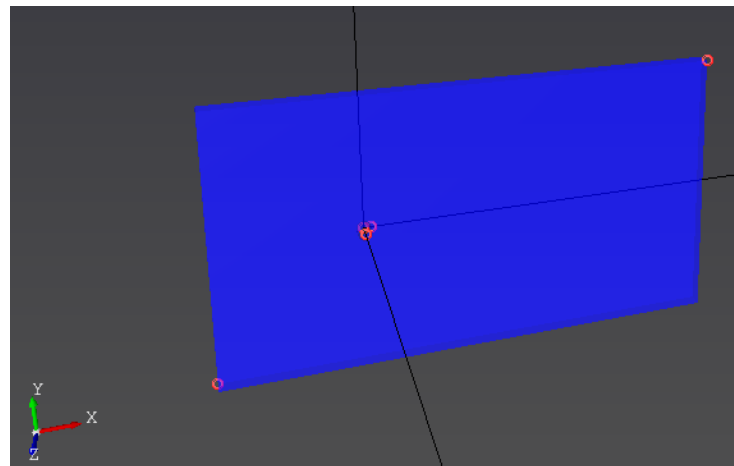

Figure 89. Created cylinder and imported fan geometry.

Name the front face **inlet**, the back face **outlet**, and the left/right faces **sym1** and top/bottom faces **sym2**. Click **To Mesh** to switch to the **Mesh** stage.

## Mesh

Use the default **Cell size** = 0.0194 m. Click **Surface**, select wall, keep the default local size and enable Layers. Add and close the dialog. Click **Volume** to refine a rectangular zone around cylinder. Select Box and enter two points:

- Start (-0.02, -0.015, 0),
- End (0.1, 0.015, 0.01).

Set the **Local size** to 0.01 m and click **Add to List** (Figure 90). Finally, click **Apply and Close**.

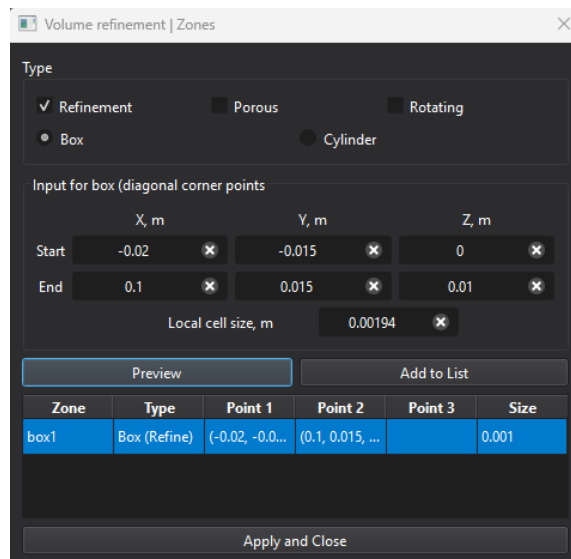

Figure 90. Mesh refinement around cylinder.

Generate mesh. Check the mesh quality plots before proceeding. The generated mesh around cylinder is shown in Figure 91.

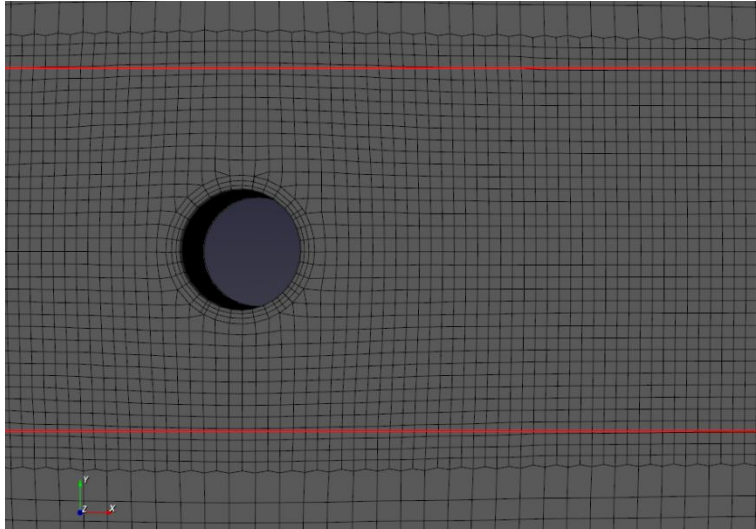

Figure 91. Generated mesh around cylinder.

Click **To Setup** to move to the next stage.

### Setup

In the **Fluid model** panel, switch to **Transient** and set:

- **Iter. per step:** 5,
- **Time step:** 0.001 s,
- **Total time:** 0.6 s,
- **Save every:** 20 iterations.

Select **Laminar** flow mode. Use the default fluid material: **Air**.

Apply the following boundary conditions (Figure 92):

- **Inlet** → inlet: velocity 1.3 m/s (x direction),
- **Outlet** → outlet: Pressure 0 Pa,
- **Wall** → wall: Regular,
- **Symmetry** → sym1, sym2.

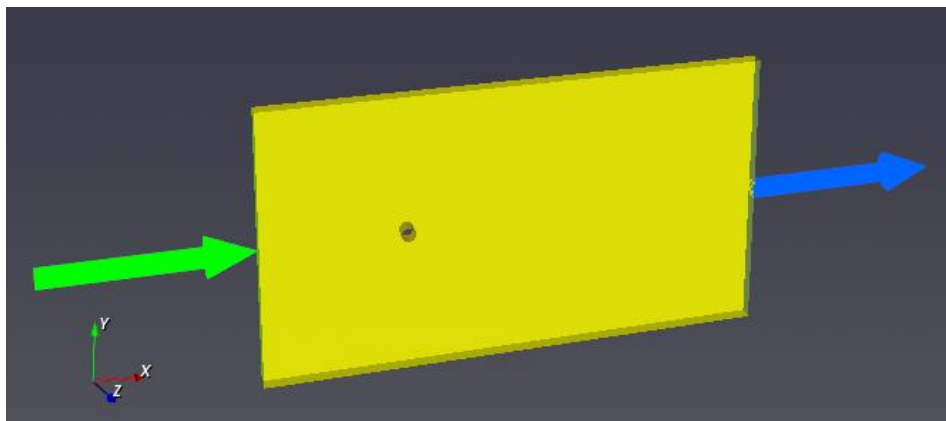

Figure 92. Boundary conditions applied.

Click **To Solution** to move to the next stage.

## Solution

Add a monitoring point at **(0.020, 0.0, 0.005)**, which is located **0.02 m** downstream from the cylinder center, and select **Umag** as the monitoring variable. Run the simulation. The convergence and monitoring graphs are shown in Figure 93.

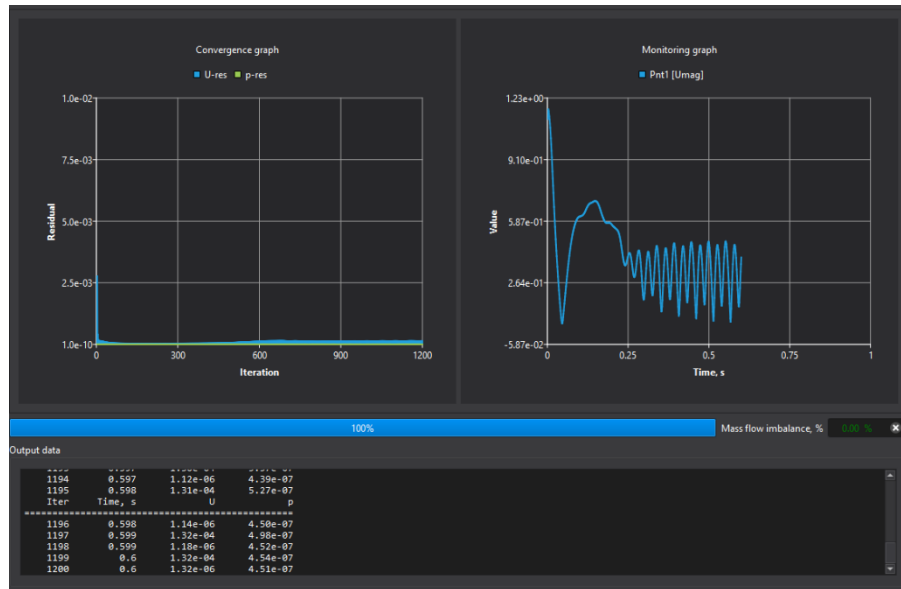

Figure 93. Convergence and monitoring graphs.

Click **To Result** to move to the next stage.

## Result

Select **sym1** and **Velocity magnitude (|U|)** (Figure 94). This plot represents the final time step at **0.6 s**.

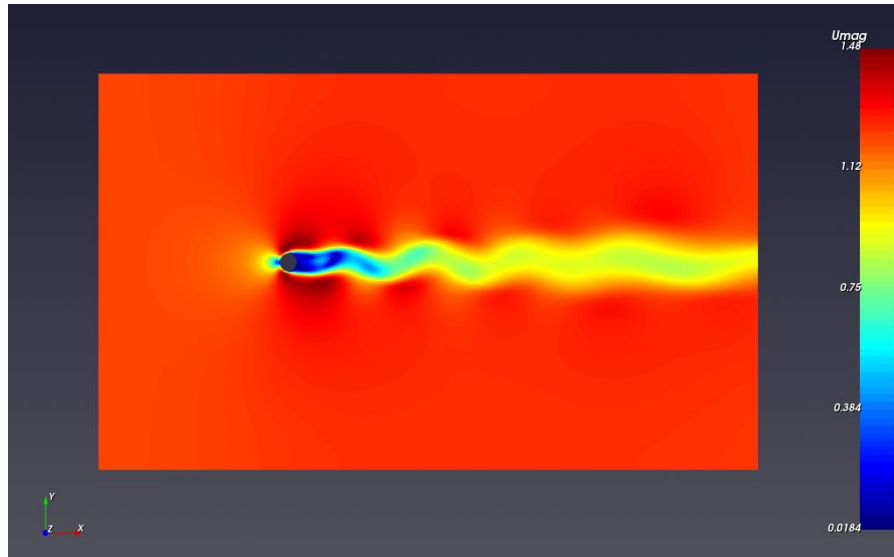

Figure 94. Velocity contour at symmetry plane.

The default time step can be changed in Post transient panel with step forward/back buttons or from the list (Figure 95).

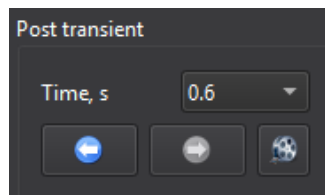

Figure 95. Post transient panel.

Click the **Animation** button. In the animation dialog, keep **Full**, set **Animation speed** around **25%** and click **Create** (Figure 96). The animation will be saved in the **Result** folder.

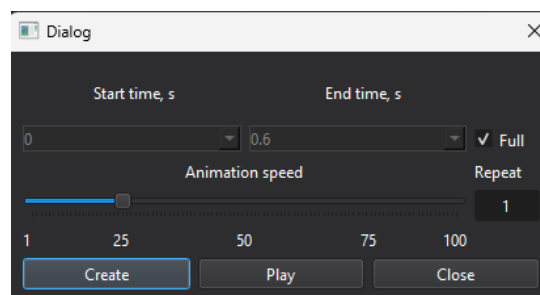

Figure 96. Animation dialog.

Click **Report** to generate the PDF report.

## Chapter II. Advanced tutorials

This chapter presents advanced example cases that demonstrate additional CFXD capabilities beyond the basic workflow, such as **rotating-flow modeling (MRF)** and **conjugate heat transfer (CHT)**. The tutorials include steady simulations and focus on multi-domain physics and zone-based models.

### 9. Flow with rotation (MRF)

This case models airflow through a pipe with a rotating fan. The system consists of a fan installed inside a pipe with diameter **D = 200 mm**. The fan rotation speed is **200 rpm**. The fluid is **air**.

#### Geometry

Import the fan geometry (fan.step). Three points required to construct the pipe (units: mm) are shown in Table 12.

Table 12: Point coordinates.

Point	Coordinates	Comments
Pnt1	(0, 0, 100)	Center point of cylinder base
Pnt2	(0, 0, -100)	Radius point of cylinder base
Pnt3	(80, 0, 100)	Height point of cylinder

Create three points and construct a cylinder from them. The created cylinder and imported fan geometry are shown in Figure 97.

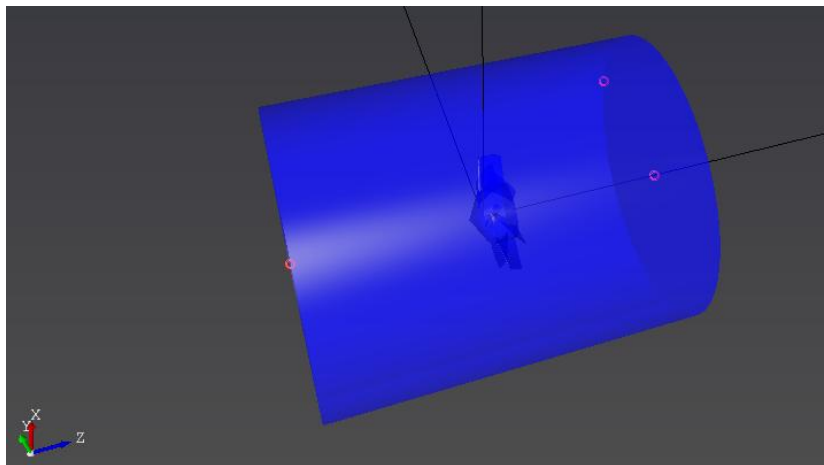

Figure 97. Created cylinder and imported fan geometry.

Use Boolean operation Subtract to extract solid body from fluid body. Name the front face **inlet**, the back face **outlet**, and the side face **wall-out**. Click **To Mesh** to switch to the **Mesh** stage.

## Mesh

Rotation modeling requires defining a **rotating volume zone** in the Mesh stage. Open **Refinement | Zones → Volume**, enable **Rotating**, and select the **Cylinder** shape. Define the cylinder using three points:

- **Center:** (0, 0, -0.03)
- **Radius point:** (0, 0.04, -0.03)
- **Height point:** (0, 0, 0.04).

Set the **Local cell size** to **0.001 m**, then click **Add to List** (Figure 98). Finally, click Apply and Close.

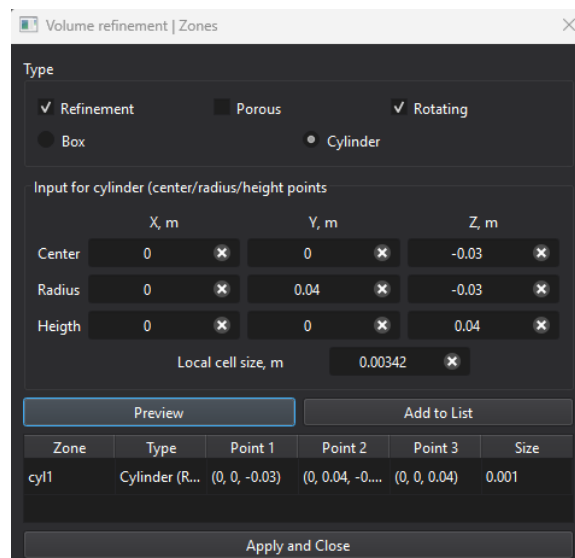

Figure 98. Rotating zone definition.

Click **Generate** to create the mesh. Inspect the mesh and review the mesh quality plots before proceeding. Use **Cut section** to examine the mesh around the fan (Figure 99).

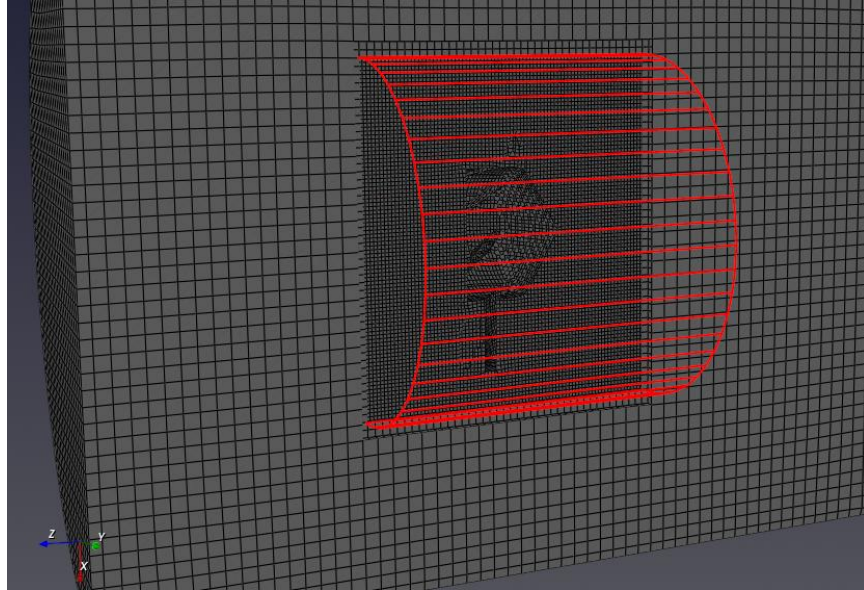

Figure 99. Generated mesh.

Click **To Setup** to move to the next stage.

### Setup

In the **Fluid model** panel, use the default **SST** turbulence model and **Incomp (M < 0.3)**. Use the default fluid material **Air**.

In the **Domains** tree click on **cyl1** under **Rotating**. In the Rotating zone dialog, set the rotational speed to 200 rpm. The rotation axis is defined automatically by the program.

Apply the following boundary conditions (Figure 100):

- **Inlet** → inlet: velocity 5 m/s (z direction), turbulent intensity 5%, length scale 0.1 m,
- **Outlet** → outlet: pressure 0 Pa,
- **Wall** → wall-out, wall: regular.

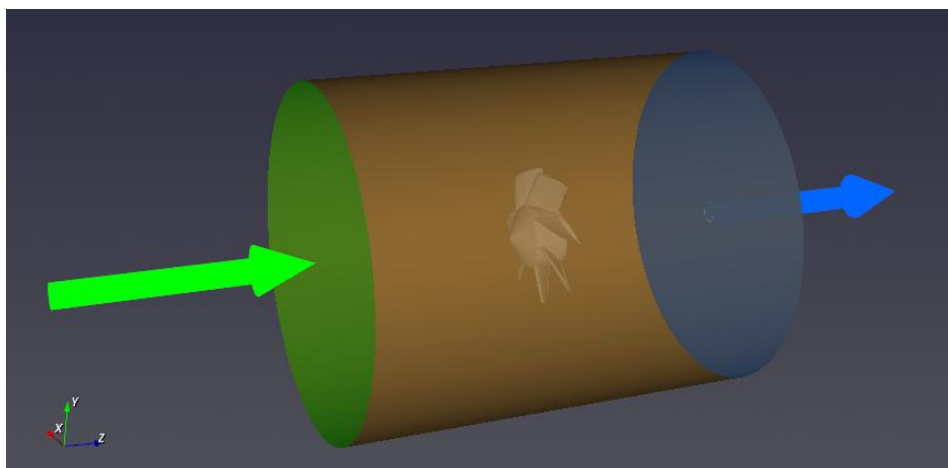

Figure 100. Boundary conditions applied.

Click **To Solution** to move to the next stage.

### Solution

Add a monitoring point at **(0.0, 0.0, 0.05)** and select **Umag** as the monitoring variable. Run the simulation. The convergence and monitoring graphs are shown in Figure 101.

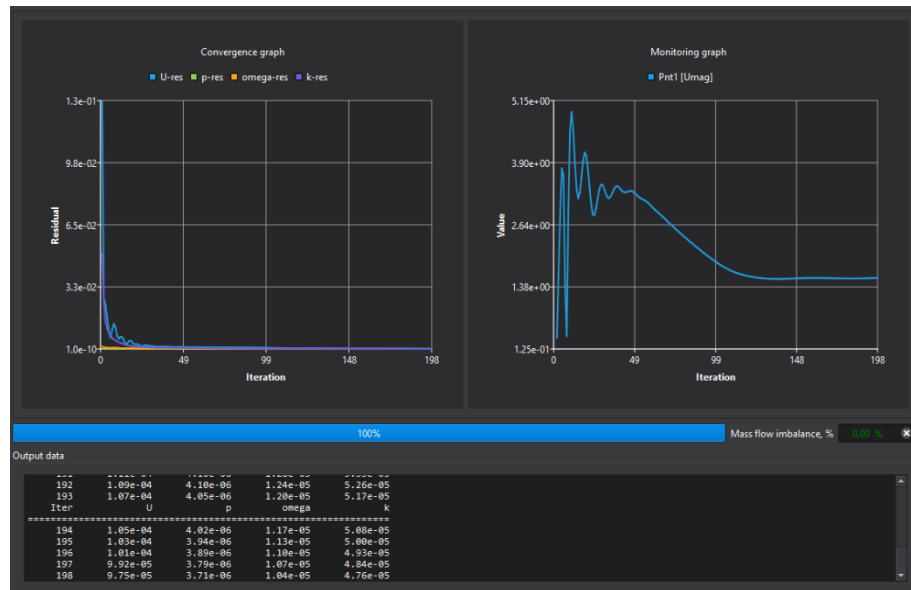

Figure 101. Convergence and monitoring graphs.

Click **To Result** to move to the next stage.

### Result

Create a default plane (XY) in **Post entities** panel and visualize Velocity magnitude ( $|U|$ ) (Figure 102).

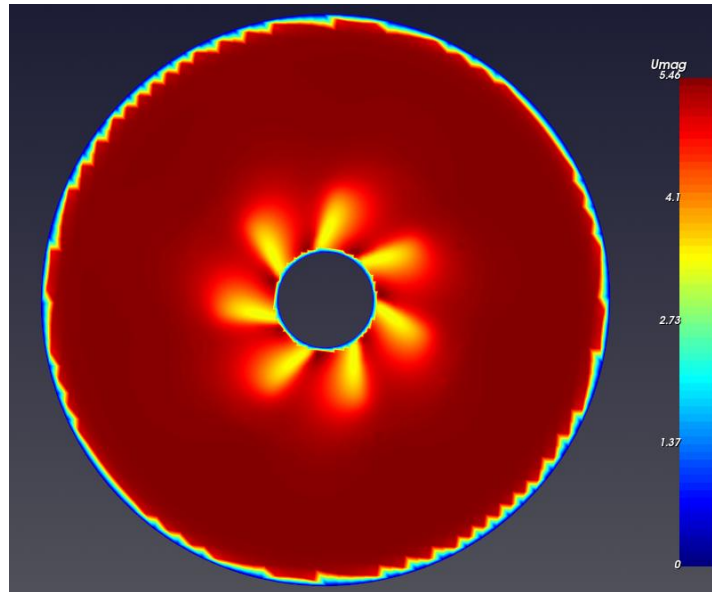

Figure 102. Velocity contour in XY plane.

Click on wall and in the dialog select **Gauge pressure** in **General** panel. In Surface/Plane report, select Report type: **Pressure force**. The calculated value is 0.039N. Click Close and show. The gauge pressure distribution on the fan is show in Figure 103.

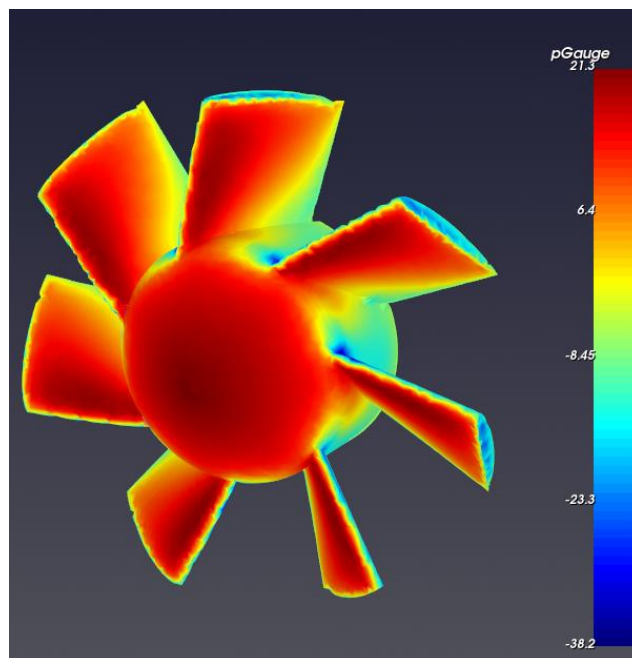

Figure 103. Gauge pressure distribution on the fan.

Click **Report** to generate the PDF report.

## 10. Conjugate heat transfer (CHT)

This case models **conjugate heat transfer** between a pipe and the flow inside it. The pipe inner diameter is **1 m**, and the wall thickness is **0.1 m**. The inlet velocity is  **$U = 2 \text{ m/s}$**  and the inlet temperature is **288 K**. The fluid is air. The outer wall temperature is **350 K**. The solid material is **steel**.

### Geometry

Choose **Conjugate heat transfer** in **Simulation type**. Four points are required to construct inner and outer cylinders. The points coordinates are listed in Table 13 (units: mm). Points **Pnt1–Pnt3** define the inner cylinder, **Pnt4–Pnt5** define the outer cylinder.

Table 13: Point coordinates.

Point	Coordinates	Comments
Pnt1	(0, 0, 0)	Center point of cylinder base
Pnt2	(0, 0.5, 0)	Radius point of inner cylinder base
Pnt3	(5, 0, 0)	Height point of cylinders
Pnt4	(0, 0.6, 0)	Radius point of outer cylinder base

Create the four points and construct two cylinders. Use the Subtract operation to subtract the inner cylinder from the outer cylinder. The created inner cylinder and outer hollow cylinder are shown in Figure 104.

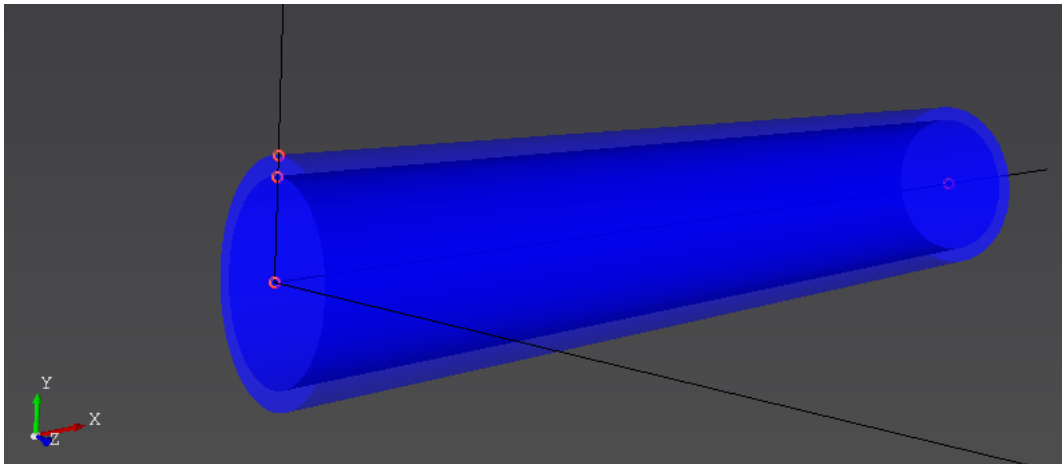

Figure 104. Created inner cylinder and outer hollow cylinder.

Name the front face of the inner cylinder **inlet**, the back face **outlet**, and the outer faces **wall-out**. Click **To Mesh** to switch to the Mesh stage.

### Mesh

Use default **Cell size = 0.0384 m**. Click **Surface**, select inlet, and set the **Local size to 0.03 m**. Repeat the same for outlet (Figure 105). Add and close the dialog.

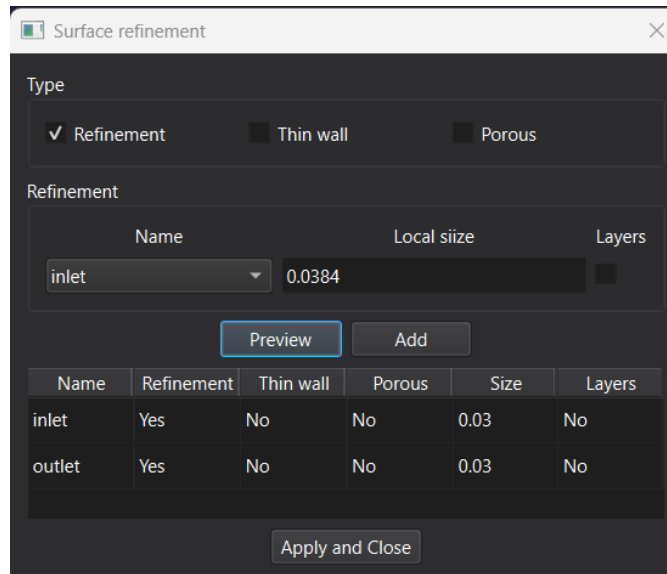

Figure 105. Mesh refinement at the inlet and outlet.

Generate mesh. Check the mesh quality plots before proceeding. Use **Cut section** to examine the mesh inside the pipe and wall region (Figure 106).

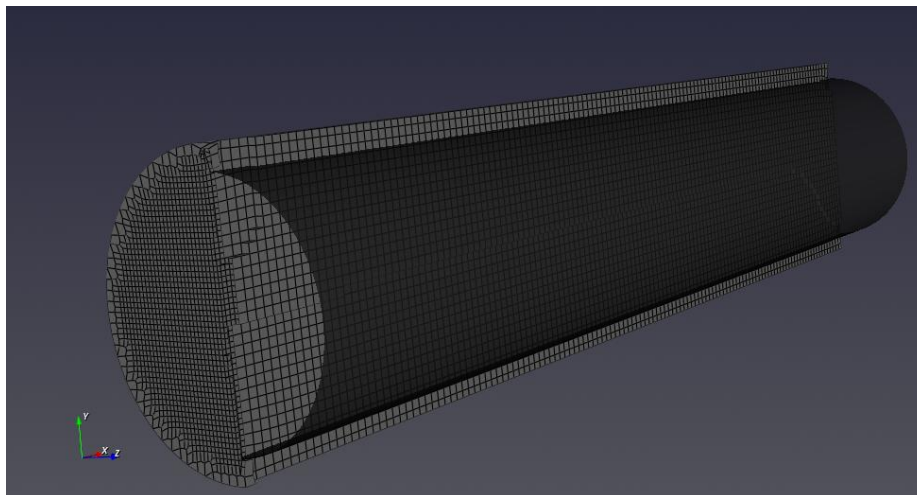

Figure 106. Generated mesh inside the pipe and wall.

Click **To Setup** to move to the next stage.

## Setup

In the **Fluid model** panel, keep the default settings: **Steady, Turbulent, SST** model and incompressible flow. The **Heat** model is enabled automatically for CHT workflow. In the **Domains** tree assign **Fluid/Air** to **Body1** and **Solid/Steel** to **Body2**.

Apply the following boundary conditions (Figure 107):

- **Inlet** → inlet: velocity 2.0 m/s (x direction),
- **Outlet** → outlet: Pressure 0 Pa,
- **Wall** → wall-out: Regular, Wall type: Temperature, Temperature: 350 K,
- **Interface** → interface: Perfect contact.

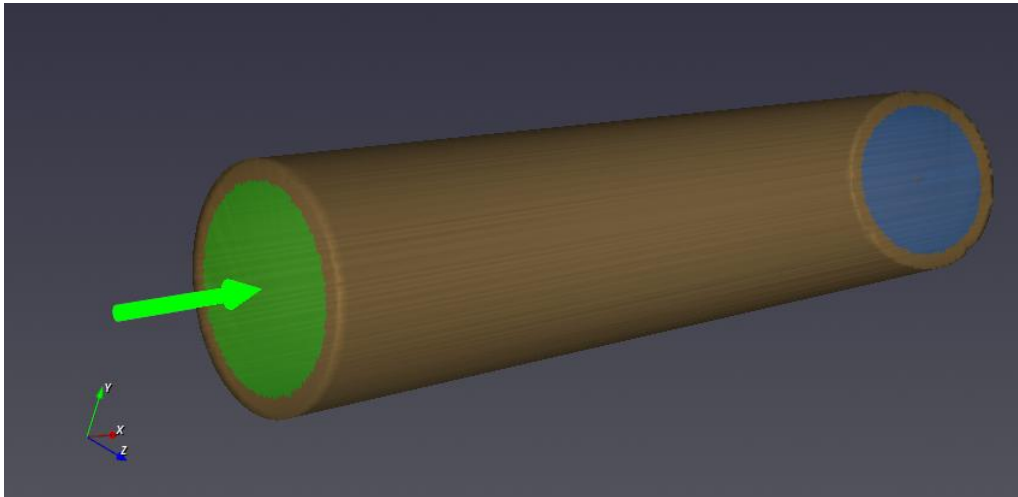

*Figure 107. Boundary conditions applied.*

Click **To Solution** to move to the next stage.

## Solution

Add a monitoring point at **(4.0, 0.0, 0.0)**, which is located **4.0 m** from the **inlet**, and select **Umag** as the monitoring variable. Run the simulation. The convergence and monitoring graphs are shown in Figure 108.

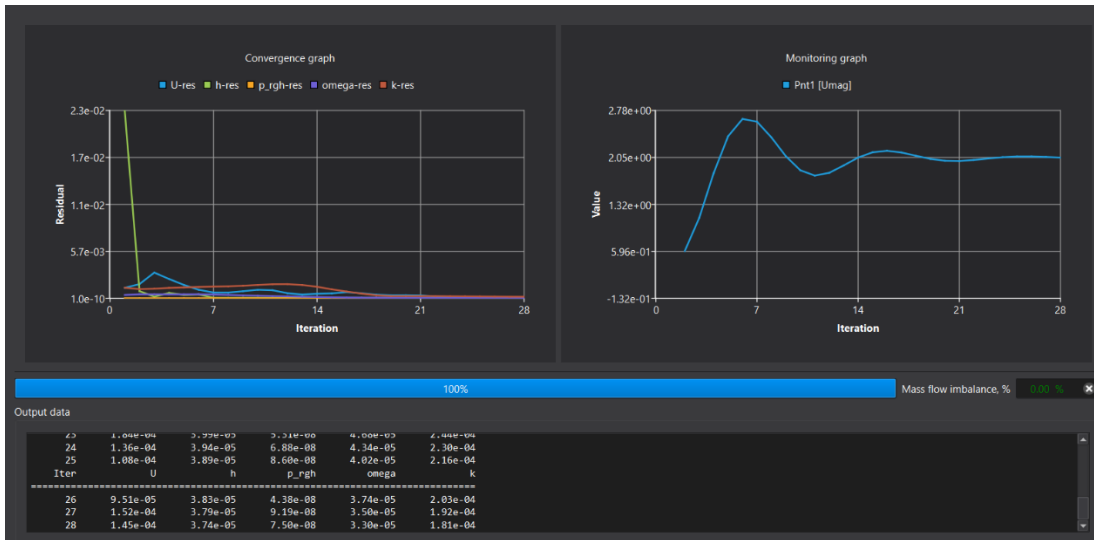

Figure 108. Convergence and monitoring graphs.

Click **To Result** to move to the next stage.

## Result

Create a default **Plane** at XY and select **Velocity magnitude (|U|)** (Figure 109).



Figure 109. Velocity contour at XY plane.

Add a **Temperature** contour on the same plane (Figure 110Figure 95).



Figure 110. Temperature contour at XY plane.

Click **Report** to generate the PDF report.

## References

1. Software user guide. (Theory and general overview)
2. Yun A. Computational Fluid Dynamics: from zero to guru. Creative Space, 2019.